

Analog Input Modules

Please note: \$US prices shown
For current \$AUD visit www.directautomation.com.au

F4-04ADS \$1,092.00 4-Channel Isolated Analog Input

Number of Channels	4
Input Ranges	0-5 V, 0-10 V, 1-5 V, ±5V, ±10V 0-20 mA, 4-20 mA
Channels Individually Configurable	Yes
Resolution	12 bit (1 to 4,096)
Conversion Method	Successive Approximation
Input Type	Differential
Max. Common Mode Voltage	± 750V peak continuous transformer isolation
Noise Rejection Ratio	Common mode: -100 dB @ 60 Hz
Active Low-pass Filtering	-3 dB at 20 Hz, -12 dB per octave
Input Impedance	250Ω ± 0.1%, 1/2W current input 200 kΩ voltage point
Absolute Maximum Ratings	-45 mA to + 45 mA, current input ± 100V voltage input
Conversion Time	1 ms per selected channel
Linearity Error:	unipolar ± 1 count (0.025% of full scale) max. bipolar ± 2 counts (0.025% of full scale) max.
Full Scale Calibration Error	± 8 counts maximum (Vin = 20 mA)
Offset Calibration Error	± 8 counts maximum (Vin = 4 mA)

PLC Update Rate	1 channel per scan
Digital Input Points Required	16 (X) input points (12 binary data bits, 4 active channel indicator bits)
Accuracy vs Temperature	± 100 ppm/°C maximum full scale (including maximum offset)
Terminal Type (included)	Removable
Base Power Required 5V	370 mA
External Power Supply	24 VDC, ± 10%, 120 mA, class 2
Recommended Fuse	0.032A, Series 217 fast-acting, current inputs
Operating Temperature	32 to 140°F (0 to 60 °C)
Accuracy vs. Temperature	±100 ppm /°C maximum full scale (including maximum offset)
Storage Temperature	-4 to +158 °F (-20 to +70 °C)
Relative Humidity	5 to 95% (non-condensing)
Environmental Air	No corrosive gases permitted
Vibration	MIL STD 810C 514.2
Shock	MIL STD 810C 516.2
Noise Immunity	NEMA ICS3-304

One count in the specification table is equal to one least significant bit of the analog data value (1 in 4,096).
NOTE 1: Shields should be grounded at signal source
NOTE 2: Unused channels should have V & C & R of the channels jumpered

See Wiring Solutions for part numbers of ZIPLink cables and connection modules compatible with this I/O module.

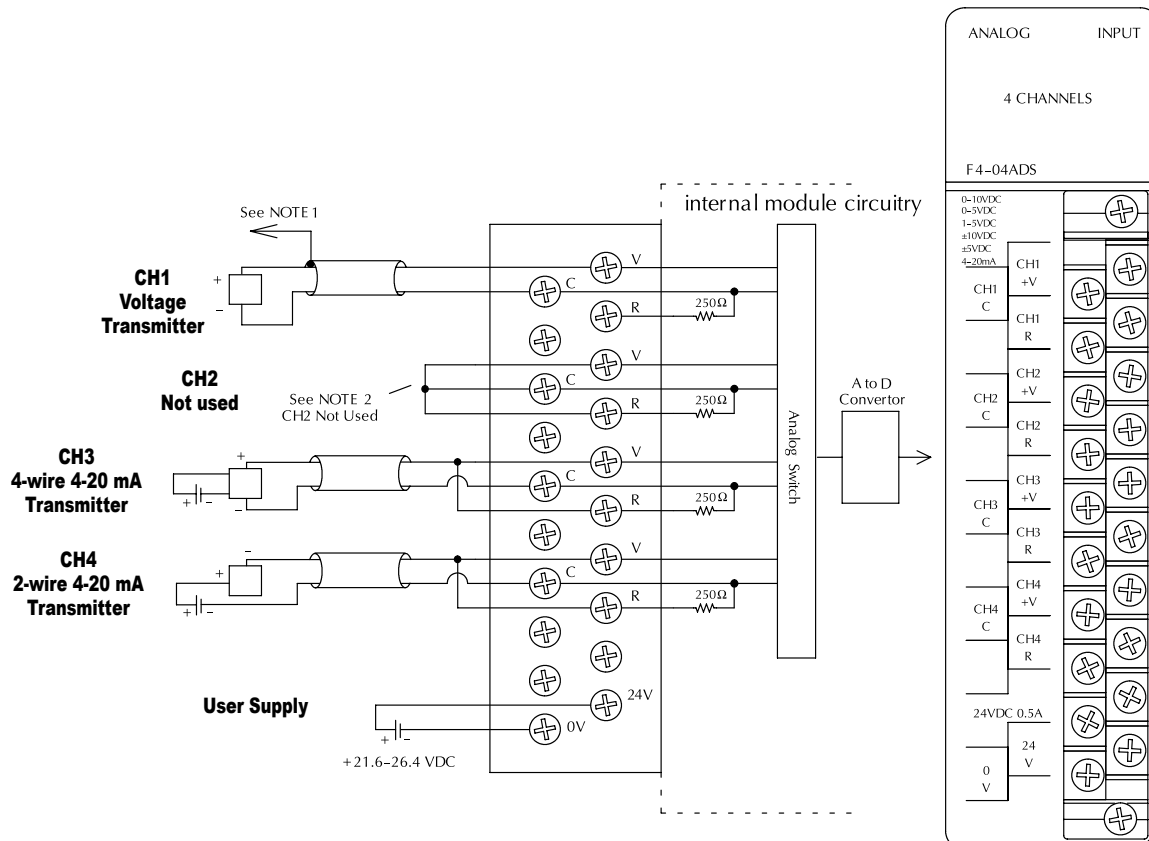

Check the Power Budget

Verify your power budget requirements

Your I/O configuration choice can be affected by the power requirements of the I/O modules you choose. When determining the types and quantity of I/O modules you will be using, it is important to remember there is a limited amount of power available from the power supply.

The chart on the opposite page indicates the power supplied and used by each DL405 device. The adjacent chart shows an example of how to calculate the power used by your particular system. These two charts should make it easy for you to determine if the devices you have chosen fit within the power budget of your system configuration.

If the I/O you have chosen exceeds the maximum power available from the power supply, you can resolve the problem by shifting some of the modules to an expansion base or remote I/O base (if you are using remote I/O).

Warning: It is extremely important to calculate the power budget correctly. If you exceed the power budget, the system may operate in an unpredictable manner which may result in a risk of personal injury or equipment damage.

Use ZIPLinks to reduce power requirements

If your application requires a lot of relay outputs, consider using the Ziplink AC or DC relay output modules. These modules can switch high current (10A) loads without putting a load on your base power budget. Refer to Wiring System for DL405 PLCs later in this section for more information.

This logo is placed next to I/O modules that are supported by the Ziplink connection systems.



See the I/O module specifications at the end of this section.

Calculating your power usage

The following example shows how to calculate the power budget for the DL405 system. The example is constructed around a single 8-slot base using the devices shown. It is recommended you construct a similar table for each base in your system.

A				
	Base Number 0	Device Type	5 VDC (mA)	External 24 VDC Power (mA)
B	CURRENT SUPPLIED			
	CPU/Expansion Unit /Remote Server	D4-454 CPU	3700	400
C	CURRENT REQUIRED			
	SLOT 0	D4-16ND2	+150	+0
	SLOT 1	D4-16ND2	+150	+0
	SLOT 2	F4-04DA-2	+90	+90
	SLOT 3	D4-08NA	+100	+0
	SLOT 4	D4-08NA	+100	+0
	SLOT 5	D4-16TD2	+100	+0
	SLOT 6	D4-16TD2	+100	+0
	SLOT 7	D4-16TR	+1000	+0
D	OTHER			
	BASE	D4-08B-1	+80	+0
	Handheld Programmer	D4-HPP-1	+320	+0
E	Maximum Current Required		2190	90
F	Remaining Current Available		3700-2190=1510	400-90=310
	1. Using a chart similar to the one above, fill in column 2. 2. Using the tables on the opposite page, enter the current supplied and used by each device (columns 3 and 4). Pay special attention to the current supplied by the CPU, Expansion Unit, and Remote Server since they differ. Devices which fall into the "Other" category (Row D) are devices such as the Base and the Handheld programmer, which also have power requirements, but do not plug directly into the base. 3. Add the current used by the system devices (columns 3 and 4) starting with Slot 0 and put the total in the row labeled "maximum current required" (Row E). 4. Subtract the row labeled "Maximum current required" (Row E), from the row labeled "Current Supplied" (Row B). Place the difference in the row labeled "Remaining Current Available" (Row F). 5. If "Maximum Current Required" is greater than "Current Supplied" in either column 3 or 4, the power budget will be exceeded. It will be unsafe to use this configuration and you will need to restructure your I/O configuration. Note the auxiliary 24 VDC power supply does not need to supply all the external power. If you need more than the 400mA supplied, you can add an external 24 VDC power supply. This will help keep you within your power budget for external power.			

DL405 CPU power supply specifications and power requirements

Specification	AC Powered Units	24 VDC Powered Units
Part Numbers	D4-454, D4-EX (expansion base unit), D4-RS (remote Server unit)	D4-454DC-1, D4-EXDC (expansion base unit)
Voltage Withstand (dielectric)	1 minute @ 1,500 VAC between primary, secondary, field ground, and run relay	
Insulation Resistance	> 10 MΩ at 500 VDC	
Input Voltage Range	85–132 VAC (110V range) 170–264 VAC (220V range)	20–28 VDC (24 VDC) with less than 10% ripple
Maximum Inrush Current	20A	20A
Maximum Power	50 VA	38W

Power Requirements

Power Supplied					
CPUs/RemoteUnits/ Expansion Units	5 VDC Current Supplied in mA	24V Aux Power Supplied in mA	CPUs/Remote Units/ Expansion Units	5V Current Supplied in mA	24V Aux Power Supplied in mA
D4-454 CPU D4-454DC-1	3100 3100	400 NONE	D4-EX D4-EXDC D4-RS H4-EBC	4000 4000 3700 3470	400 NONE 400 400
Power Consumed					
Power-consuming Device	5V Current Consumed	External 24 VDC Current Required	Power-consuming Device	5V Current Consumed	External 24 VDC Current Required
I/O Bases			Analog Modules (continued)		
D4-04B-1 D4-06B-1 D4-08B-1	80 80 80	NONE NONE NONE	F4-16AD-1 F4-16AD-2 F4-08DA-1 F4-08DA-2 F4-04DAS-1 F4-08DA-1 F4-08DA-2 F4-16DA-1 F4-16DA-2 F4-08RTD F4-08THM-J(-n) F4-08THM	75 75 70 90 60 90 80 90 80 80 120 110	100 100 75+20 per circuit 90 60 per circuit 100+20 per circuit 150 100+20 per circuit 25 max. NONE 50 60
DC Input Modules			Remote I/O		
D4-16ND2 D4-16ND2F D4-32ND3-1 D4-64ND2	150 150 150 300 max.	NONE NONE NONE NONE	H4-ERM100 H4-ERM-F D4-RM	320(300) 450 300	NONE NONE NONE
AC Input Modules			Communications and Networking		
D4-08NA D4-16NA	100 150	NONE NONE	H4-ECOM100 D4-DCM F4-MAS-MB	300 500 235	NONE NONE NONE
AC/DC Input Modules			CoProcessors		
D4-16NE3	150	NONE	F4-CP128-1	305	NONE
DC Output Modules			Specialty Modules		
D4-16TD1 D4-16TD2 D4-32TD1 D4-32TD2 D4-64TD1	200 400 250 350 800	125 NONE 140 120 (4A max including loads) NONE	H4-CTRIO D4-16SIM F4-4LTC	400 150 280	NONE NONE 75
AC Output Modules			Programming		
D4-08TA D4-16TA	250 450	NONE NONE	D4-HPP-1 (Handheld Prog.)	320	NONE
Relay Output Modules			Operator Interface		
D4-08TR F4-08TRS-1 F4-08TRS-2 D4-16TR	550 575 575 1000	NONE NONE NONE NONE	C-more Micro-Graphic	210	NONE
Analog Modules					
F4-04AD F4-04ADS F4-08AD	150 370 75	100 120 90			



Wiring Solutions

Wiring Solutions using the ZIPLink Wiring System

ZIPLinks eliminate the normally tedious process of wiring between devices by utilizing prewired cables and DIN rail mount connector modules. It's as simple as plugging in a cable connector at either end or terminating wires at only one end. Prewired cables keep installation clean and efficient, using half the space at a fraction of the cost of standard terminal blocks. There are several wiring solutions available when using the **ZIPLink** System ranging from PLC I/O-to-**ZIPLink** Connector

Modules that are ready for field termination, options for connecting to third party devices, GS, DuraPulse and SureServo Drives, and specialty relay, transorb and communications modules. Pre-printed I/O-specific adhesive label strips for quick marking of **ZIPLink** modules are provided with **ZIPLink** cables. See the following solutions to help determine the best **ZIPLink** system for your application.

Solution 1: DirectLOGIC I/O Modules to ZIPLink Connector Modules

When looking for quick and easy I/O-to-field termination, a **ZIPLink** connector module used in conjunction with a prewired **ZIPLink** cable, consisting of an I/O terminal block at one end and a multi-pin connector at the other end, is the best solution.

Using the PLC I/O Modules to **ZIPLink** Connector Modules selector tables located in this section,

1. Locate your I/O module/PLC.
2. Select a **ZIPLink** Module.
3. Select a corresponding **ZIPLink** Cable.



Solution 2: DirectLOGIC I/O Modules to 3rd Party Devices

When wanting to connect I/O to another device within close proximity of the I/O modules, no extra terminal blocks are necessary when using the **ZIPLink** Pigtail Cables. **ZIPLink** Pigtail Cables are prewired to an I/O terminal block with color-coded pigtail with soldered-tip wires on the other end.

Using the I/O Modules to 3rd Party Devices selector tables located in this section,

1. Locate your PLC I/O module.
2. Select a **ZIPLink** Pigtail Cable that is compatible with your 3rd party device.



Solution 3: GS Series and DuraPulse Drives Communication Cables

Need to communicate via Modbus RTU to a drive or a network of drives?

ZIPLink cables are available in a wide range of configurations for connecting to PLCs and SureServo, SureStep, Stellar Soft Starter and AC drives. Add a **ZIPLink** communications module to quickly and easily set up a multi-device network.

Using the Drives Communication selector tables located in this section,

1. Locate your Drive and type of communications.
2. Select a **ZIPLink** cable and other associated hardware.





Wiring Solutions

Solution 4: Serial Communications Cables

ZIPLink offers communications cables for use with DirectLOGIC, CLICK, and Productivity3000 CPUs, that can also be used with other communications devices. Connections include a 6-pin RJ12 or 9-pin, 15-pin and 25-pin D-sub connectors which can be used in conjunction with the RJ12 or D-Sub Feedthrough modules.

Using the Serial Communications Cables selector table located in this section,

1. Locate your connector type
2. Select a cable.



Solution 5: Specialty ZIPLink Modules

For additional application solutions, **ZIPLink** modules are available in a variety of configurations including stand-alone relays, 24 VDC and 120 VAC transorb modules, D-sub, RJ12 and RJ45 feedthrough modules, communication port adapter and distribution modules, and SureServo 50-pin I/O interface connection.

Using the **ZIPLink** Specialty Modules selector table located in this section,

1. Locate the type of application.
2. Select a **ZIPLink** module.



Solution 6: ZIPLink Connector Modules to 3rd Party Devices

If you need a way to connect your device to terminal blocks without all that wiring time, then our pigtail cables with color-coded soldered-tip wires are a good solution. Used in conjunction with any compatible **ZIPLink** Connector Modules, a pigtail cable keeps wiring clean and easy and reduces troubleshooting time.

Using the Universal Connector Modules and Pigtail Cables table located in this section,

1. Select module type.
2. Select the number of pins.
3. Select cable.





PLC I/O Modules to ZIPLink Connector Modules - DL405

DL405 PLC Input Module ZIPLink Selector				
PLC	ZIPLink			
Input Module	# of Terms	Component	Module Part No.	Cable Part No.
D4-16ND2	20	See Note 3		
D4-16ND2F				
D4-32ND3-1²	40	Feedthrough	ZL-RTB40 (-1)	straight conn: ZL-D24-CBL40
		Sensor	ZL-LTB32-24-1	ZL-D24-CBL40-1
		Feedthrough	ZL-RTB40 (-1)	ZL-D24-CBL40-2
D4-64ND2^{1,2}		Sensor	ZL-LTB32-24-1	45 deg conn: ZL-D24-CBL40-X ZL-D24-CBL40-1X ZL-D24-CBL40-2X
D4-08NA	11	See Note 3		
D4-16NA	20			
D4-16NE3				

DL405 PLC Output Module ZIPLink Selector				
PLC	ZIPLink			
Output Module	# of Terms	Component	Module Part No.	Cable Part No.
D4-16TD1	20	See Note 3		
D4-16TD2				
D4-32TD1²	40	Feedthrough	Feedthrough ZL-RTB40 (-1) Fused ZL-RFU40⁴	straight conn: ZL-D24-CBL40
		Fuse		ZL-D24-CBL40-1
D4-32TD2²		Feedthrough		ZL-D24-CBL40-2
		Fuse		
D4-64TD1^{1,2}		Feedthrough		45 deg conn: ZL-D24-CBL40-X ZL-D24-CBL40-1X ZL-D24-CBL40-2X
		Fuse		
D4-08TA	11	See Note 3		
D4-16TA	20			
D4-08TR	11			
F4-08TRS-1	20			
F4-08TRS-2				
D4-16TR				

DL405 PLC Analog Module ZIPLink Selector				
PLC	ZIPLink			
Analog Module	# of Terms	Component	Module	Cable
F4-04AD	20	See Note 3		
F4-04ADS				
F4-08AD				
F4-16AD-1				
F4-16AD-2				
F4-04DA-1				
F4-04DA-2				
F4-08DA-1				
F4-16DA-1				
F4-08DA-2				
F4-16DA-2				
F4-04DAS-1				
F4-08THM				
F4-08THM-n				
F4-08RTD	Matched Only			

Tables Footnotes:

- The [D4-64ND2](#) and [D4-64TD1](#) modules have two 32-point connectors and require two ZIPLink cables and two ZIPLink connector modules.
- To make a custom cable for the 32 or 64-point modules, use: Ribbon-style Connector [ZL-D24-CON-R](#), Solder-style 180° connector [ZL-D24-CON](#) or Solder-style 45° connector [ZL-D24-CON-X](#)
- These modules are not supported by the ZIPLink wiring system.
- Note: Fuses (5 x 20mm) are not included. See Edison Electronic Fuse section for (5 x 20mm) fuse. S500 and GMA electronic circuit protection for fast-acting maximum protection. S506 and GMC electronic circuit protection for time-delay performance. Ideal for inductive circuits. To ensure proper operation, do not exceed the voltage and current rating of ZIPLink module. [ZL-RFU20](#) = 2A per circuit; [ZL-RFU40](#) = 400 mA per circuit.



Note: ZIPLink Connector Module specifications follow the Compatibility Matrix tables in the ZIPLink section.