

# CLICK Stackable I/O Module Specifications

Please note: \$US prices shown

For current \$AUD visit [www.directautomation.com.au](http://www.directautomation.com.au)

## CO-04RTD \$217.00

### 4-Channel RTD Input Module

4-channel RTD input module, 16-bit resolution (+/-0.1 degrees Celsius or Fahrenheit), supports: Pt100, Pt1000, JPt100, Cu10, Cu25, Ni120. Resistive ranges also supported, removable terminal block included (replacement AutomationDirect p/n [CO-16TB](#)).



**NOTE:** The [CO-04RTD](#) module cannot be used with thermistors.

### Wiring Diagram

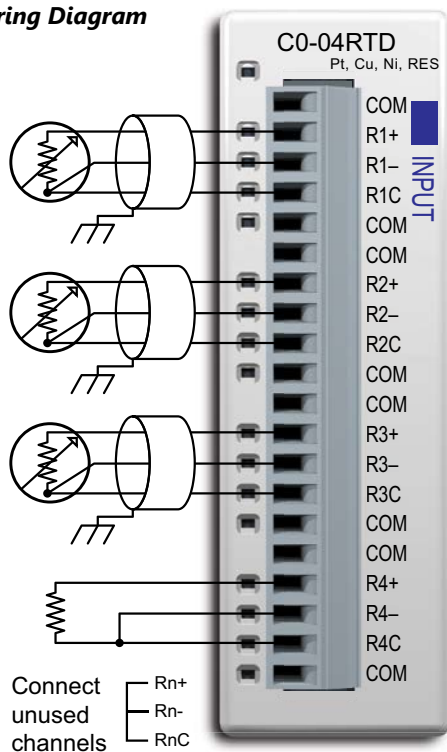

These COM terminals are isolated.



**NOTE:** When using this module you must also use CLICK programming software and PLC firmware version V1.40 or later.



**NOTE:** When this module is used in a CLICK PLC system, it may take up to 24 seconds for initialization after power-up (see the table below). During this time period, the RUN LED on the PLC Unit blinks to indicate the initialization process.

### CO-04RTD Initialization Time

The Number of Channels Used	The same Input Type is selected for all Channels	Mixed Input Types are selected
1	4 sec	N/A
2	5 sec	May take up to 13 sec
3	6 sec	May take up to 18 sec
4	7 sec	May take up to 24 sec

Input Specifications	
Inputs per Module	4
Common Mode Range	±2.5 V
Common Mode Rejection	100dB at DC and 100 dB at 50/60Hz
Input Impedance	>5MΩ
Maximum Ratings	Fault protected inputs to ±50VDC
Resolution	±0.1°C or °F, 0.1 Ω or 0.01 Ω
Input Ranges*	Pt100: -200 to 850°C [-328 to 1562°F] Pt1000: -200 to 595°C [-328 to 1103°F] JPt100: -100 to 450°C [-148 to 842°F] 10Ω Cu: -200 to 260°C [-328 to 500°F] 25Ω Cu: -200 to 260°C [-328 to 500°F] 120Ω Ni: -80 to 260°C [-112 to 500°F] 0 to 3125.0 Ω : Resolution 0.1 Ω 0 to 1562.5 Ω : Resolution 0.1 Ω 0 to 781.2 Ω : Resolution 0.1 Ω 0 to 390.62 Ω : Resolution 0.01 Ω 0 to 195.31 Ω : Resolution 0.01 Ω
RTD Linearization	Automatic
Excitation Current (All Ranges)	210 μA
Accuracy vs. Temperature	±10ppm per °C maximum
RTD Input Maximum Inaccuracy	±3°C (excluding RTD error); ±5°C (ranges Cu10 and Cu25)
RTD Linearity Error (End to End)	±2°C maximum, ±0.5°C typical, monotonic with no missing codes
Resistance Input Maximum Zero Scale Error	±0.0015% of full scale range in ohms (negligible)
Resistance Input Maximum Full Scale Error	±0.02% of full scale range
Maximum Linearity Error	±0.015% of full scale range maximum at 25°C, monotonic with no missing codes
Resistance Maximum Input Inaccuracy	0.1% at 0 to 60°C (32° to 140° F), typical 0.04% at 25°C (77° F)
Warm Up Time	30 minutes for ±1°C repeatability
Single Channel Update Rate	240ms
All Channel Update Rate	Single Channel Update Rate times the number of enabled channels on the module
Open Circuit Detection Time	Positive full-scale reading within 2 seconds
Conversion Method	Sigma - Delta

\* While it is possible to use different resistive ranges, we recommend using the narrowest range that covers the resistance being measured. For example, if measuring approximately 100 ohms resistance, use the 0 to 195.31 ohms range. While the resolution is the same as the 0 to 390.62 ohms range, output RMS noise will be lower and stability will be improved.

### General Specifications

Field to Logic Side Isolation	No isolation
External DC Power Required	None
Bus Power Required (24VDC)	25mA
Thermal Dissipation	2.047 BTU per hour
Terminal Block Replacement	AutomationDirect p/n <a href="#">CO-16TB</a>
Drawing Link	PDF
Weight	3.1 oz [86g]

Not Compatible with ZIPLink Pre-Wired PLC Connection Cables and Modules.



# CLICK Stackable I/O Module Specifications

## General Specifications For All CLICK Stackable I/O Modules

These general specifications apply to all CLICK Stackable I/O Modules. Please refer to the appropriate I/O temperature derating charts under the PLC (CLICK PLC with built-in I/O), Option Slot module (CLICK PLUS only), and Stackable I/O module specification to determine best operating conditions based on the ambient temperature of your particular application.



**NOTE:** These modules are available to use with CLICK or CLICK PLUS systems.

General Specifications	
<b>Operating Temperature</b>	Analog, analog combo I/O modules only: 32°F to 140°F [0°C to 60°C]; All other modules: 32°F to 131°F [0°C to 55°C], IEC 60068-2-14 (Test Nb, Thermal Shock)
<b>Storage Temperature</b>	-4°F to 158°F [-20°C to 70°C] IEC 60068-2-1 (Test Ab, Cold) IEC 60068-2-2 (Test Bb, Dry Heat) IEC 60068-2-14 (Test Na, Thermal Shock)
<b>Ambient Humidity</b>	30% to 95% relative humidity (non-condensing)
<b>Environmental Air</b>	No corrosive gases. Environmental pollution level is 2 (UL840)
<b>Vibration</b>	MIL STD 810C, Method 514.2, EC60068-2-27, Category [f], Procedure[VIII] JIS C60068-2-27 (Sine wave vibration test)
<b>Shock</b>	MIL STD 810C, Method 516.2, IEC60068-2-27, JIS C60068-2-27, Category [f], Procedure[VIII]
<b>Noise Immunity</b>	<EN61131-2> EN61000-4-2 (ESD) EN61000-4-3 (RFI) EN61000-4-4 (FTB) EN61000-4-5 (Surge) EN61000-4-6 (Conducted) EN61000-4-8 (Power frequency magnetic field immunity)  <Local Test> Impulse noise 1μs, 1000V RFI: No interference measured at 150 and 450 MHz (5w/15cm)
<b>Emissions</b>	EN55011:1998 Class A; EN61000-6-4:2007+A1:2011
<b>Agency Approvals</b>	UL508, UL61010-2-201 (File No. E157382, E316037); CE (EN61131-2); CUL Canadian C22.2
<b>Other</b>	RoHS 2011/65/EU Amendment (EU)2015/863

# Power Supplies

## Power Supplies

The CLICK PLC family offers two 24VDC power supplies. They are identical except for the output current.

It is not mandatory to use one of these CLICK power supplies for the CLICK/CLICK PLUS PLC system. You can use any other 24VDC power supply that AutomationDirect.com offers, including the PSP24-DC12-1 12 to 24 VDC converter shown below.

### CO-00AC Power Supply

Limited auxiliary AC power supply allows you to power the 24VDC CLICK C0 and C2 series PLCs with 100–240 VAC supply power. The 0.5 A DC power supply is capable of controlling the PLC plus a limited configuration based on the power budget of each I/O module. The CO-00AC is a low-cost solution for applications requiring only minimal I/O and power consumption. This power supply will not support a fully-populated CLICK PLC system with all possible I/O module combinations.

### CO-01AC Power Supply

Expanded auxiliary AC power supply allows you to power the 24VDC CLICK C0 and C2 series PLCs with 100–240 VAC supply power. The 1.3 A DC power supply is capable of supporting a fully-populated CLICK PLC system with all possible I/O module combinations, with no concerns for exceeding the power budget.

### PSP24-DC12-1 DC-DC Converter

With this DC-DC converter you can operate the CLICK/CLICK PLUS PLC with 12VDC input power.

CO-00AC



CO-01AC



CLICK 24VDC Power Supply Ratings		
Part Number	Output Current	Price
CO-00AC	0.5 A	\$51.00
CO-01AC	1.3 A	\$63.00

Power Supply Input Specifications		
Part Number	CO-00AC	CO-01AC
Input Voltage Range	85–264 VAC	
Input Frequency	47–63 Hz	
Input Current (typical)	0.3 A @ 100VAC, 0.2 A @ 200VAC	0.9 A @ 100VAC, 0.6 A @ 200VAC
Inrush Current	30A	
Efficiency	80% typical	

Power Supply Output Specs		
Part Number	CO-00AC	CO-01AC
Output Voltage Range	23–25 VDC	
Output Current	0.5 A	1.3 A
Ripple	200mV p-p max (0–55°C)	
Ripple Noise	300mV p-p max (0–55°C)	
Over Current Protection	@ 0.65 A (automatic recovery)	@ 1.6 A (automatic recovery)
Over Voltage Protection	@ 27.6 V (clamped by Zener diode)	
Start-up Time	1000ms max at rated input and load	
Hold-up Time	10ms minimum at 85VAC, I=max	

Power Supply General Specs		
Part Number	CO-00AC	CO-01AC
Ambient Operating Temperature	32–131°F [0–55°C]	
Storage Temperature	–4–158°F [–20–70°C]	
Humidity	30–95%, non-condensing	
Vibration Resistance	JIS C60068-2-6, sine wave vibration	
Shock Resistance	JIS C60068-2-27	
Voltage Withstand	1500VAC, 5mA cutoff current	
Input-Output	1500VAC, 5mA cutoff current	
Input-Ground	500VAC, 5mA cutoff current	
Output-Ground	500VAC, 5mA cutoff current	
Insulation Resistance	10MΩ minimum, 500VDC	
Input-Output	10MΩ minimum, 500VDC	
Input-Ground	5MΩ minimum, 500VDC	
Output-Ground	5MΩ minimum, 500VDC	
Noise Immunity	FCC Class A, EN55022:1998 Class A	
Input/Output Interface	5P terminal block, Fujicon UF2362AX series or equivalent	
Agency Approvals	UL508, UL1604, EN61010-1 (IEC 1010-1), CAN/CSA E60079-15:02, JIS C0025	
Drawing Link	<a href="#">PDF</a>	<a href="#">PDF</a>
Weight	5.3 oz [150g]	6.0 oz [170g]

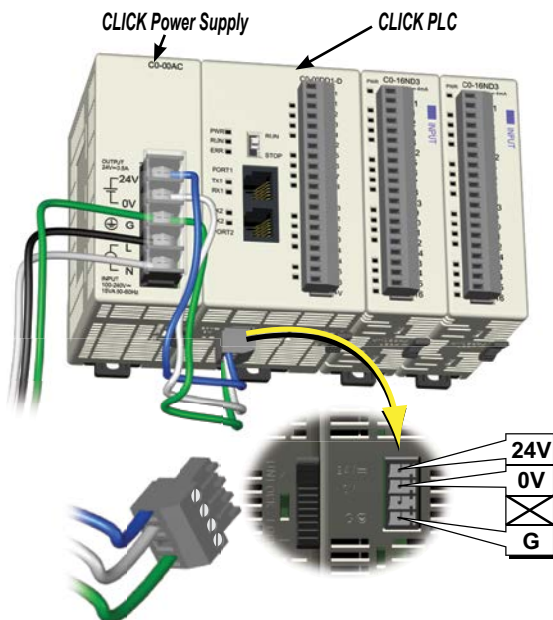

24VDC power is supplied to the PLC unit through wiring connected from the power supply output to the 4-pin 24VDC input connector located on the bottom of the PLC unit.



PSP24-DC12-1

PSP24-DC12-1 DC-DC Converter Specs	
Input Voltage Range	9.5–18 VDC
Input Power (no load)	1.0 W max.
Startup Voltage	8.4 VDC
Undervoltage Shutdown	7.6 VDC
Output Voltage Range	24–28 VDC (adjustable)
Output Current	1.0 A
Short Circuit Protection	Current limited at 110% typical
Drawing Link	<a href="#">PDF</a>
Weight	7.5 oz [213g]

# Power Budgeting

## Power Budgeting

There are two factors to consider when determining the power required to operate a CLICK PLC system. The first is the power required by the PLC and internal logic-side power provided through the PLC. This includes the CPU's own I/O, any connected I/O modules that are powered through the PLC expansion port, plus any device, such as a **C-more** Micro-Graphic panel, that is powered through one of the communications ports.

The second area is the power required by all externally-connected I/O devices. This should be viewed as the field-side power required. The field-side power is dependent on the voltage used for a particular input or output device as it relates to the wired I/O point and to the calculated load rating of the connected device.

It is strongly recommended that the power source for the logic side be separate from the power source for the field side to help eliminate possible electrical noise.

Power budgeting requires the calculation of the total current the 24VDC power source needs to provide to CLICK's logic side. A separate calculation is required to determine the total current required for all devices operating from the field side of the PLC system.

Refer to the Power Budgeting example shown on the following page. The table shows required current for a CLICK PLUS PLC, two I/O modules, and a **C-more** Micro. Use the total amperage values to select a suitable power supply.



**CLICK 24VDC Power Supply**  
C0-00AC or C0-01AC



**Other 24VDC Power Supply**  
Example: PSP24-060S

## Power Consumption for CLICK and CLICK PLUS PLC Units

## Power Consumption for CLICK PLUS Option Slot Modules

PLC Current Consumption (mA)		
Part Number	Power Budget 24VDC (Logic Side)	External 24VDC (Field Side)
<b>Basic PLC Units</b>		
<a href="#">C0-00DD1-D</a>	120	60
<a href="#">C0-00DD2-D</a>	120	0
<a href="#">C0-00DR-D</a>		
<a href="#">C0-00AR-D</a>		
<b>Standard PLC Units</b>		
<a href="#">C0-01DD1-D</a>	140	60
<a href="#">C0-01DD2-D</a>	140	0
<a href="#">C0-01DR-D</a>		
<a href="#">C0-01AR-D</a>		
<b>Analog PLC Units</b>		
<a href="#">C0-02DD1-D</a>	140	60
<a href="#">C0-02DD2-D</a>	140	0
<a href="#">C0-02DR-D</a>		
<b>Ethernet Basic PLC Units</b>		
<a href="#">C0-10DD1E-D</a>	120	60
<a href="#">C0-10DD2E-D</a>	120	0
<a href="#">C0-10DRE-D</a>		
<a href="#">C0-10ARE-D</a>		
<b>Ethernet Standard PLC Units</b>		
<a href="#">C0-11DD1E-D</a>	140	60
<a href="#">C0-11DD2E-D</a>	140	0
<a href="#">C0-11DRE-D</a>		
<a href="#">C0-11ARE-D</a>		

PLC Current Consumption (mA)		
Part Number	Power Budget 24VDC (Logic Side)	External 24VDC (Field Side)
<b>Ethernet Analog PLC Units</b>		
<a href="#">C0-12DD1E-D</a>	140	60
<a href="#">C0-12DD2E-D</a>		
<a href="#">C0-12DRE-D</a>	160	0
<a href="#">C0-12ARE-D</a>		
<a href="#">C0-12DD1E-1-D</a>	140	60
<a href="#">C0-12DD2E-1-D</a>		
<a href="#">C0-12DRE-1-D</a>	160	0
<a href="#">C0-12ARE-1-D</a>		
<a href="#">C0-12DD1E-2-D</a>	140	60
<a href="#">C0-12DD2E-2-D</a>		
<a href="#">C0-12DRE-2-D</a>	160	0
<a href="#">C0-12ARE-2-D</a>		
<b>CLICK PLUS PLCs</b>		
<a href="#">C2-01CPU</a>	110	0
<a href="#">C2-01CPU-2</a>	120	
<a href="#">C2-02CPU</a>	105	
<a href="#">C2-02CPU-2</a>	115	
<a href="#">C2-03CPU</a>	130	
<a href="#">C2-03CPU-2</a>	140	

CLICK PLUS Option Slot Modules Current Consumption (mA)		
Part Number	Power Budget 24VDC (Logic Side)	External 24VDC (Field Side)
<b>Option Slot I/O Modules</b>		
<a href="#">C2-14D1</a>	50	60
<a href="#">C2-14D2</a>	50	0
<a href="#">C2-14DR</a>	75	0
<a href="#">C2-14AR</a>	75	0
<a href="#">C2-08D1-4VC</a>	80	60
<a href="#">C2-08D2-4VC</a>	80	0
<a href="#">C2-08DR-4VC</a>	100	0
<a href="#">C2-08AR-4VC</a>	100	0
<a href="#">C2-08D1-6C</a>	80	60
<a href="#">C2-08D2-6C</a>	80	0
<a href="#">C2-08DR-6C</a>	100	0
<a href="#">C2-08AR-6C</a>	100	0
<a href="#">C2-08D1-6V</a>	80	60
<a href="#">C2-08D2-6V</a>	80	0
<a href="#">C2-08DR-6V</a>	100	0
<a href="#">C2-08AR-6V</a>	100	0
<b>Option Slot Intelligent Modules</b>		
<a href="#">C2-DCM</a>	60	0

# Power Budgeting

## Power Consumption for CLICK Stackable I/O Modules

I/O Module Current Consumption (mA)		
Part Number	Power Budget 24VDC (logic side)	External 24VDC (field side)
<b>Discrete Input Modules</b>		
<a href="#">C0-08SIM</a>	50	0
<a href="#">C0-08ND3</a>	30	0
<a href="#">C0-08ND3-1</a>	30	0
<a href="#">C0-16ND3</a>	40	0
<a href="#">C0-08NE3</a>	30	0
<a href="#">C0-16NE3</a>	40	0
<a href="#">C0-08NA</a>	30	0
<b>Discrete Output Modules</b>		
<a href="#">C0-08TD1</a>	50	15
<a href="#">C0-08TD2</a>	50	0
<a href="#">C0-16TD1</a>	80	100
<a href="#">C0-16TD2</a>	80	0
<a href="#">C0-08TA</a>	80	0
<a href="#">C0-04TRS</a>	100	0
<a href="#">C0-04TRS-10</a>	120	0
<a href="#">C0-08TR</a>	100	0
<a href="#">C0-08TR-3</a>	90	0

I/O Module Current Consumption (continued) (mA)		
Part Number	Power Budget 24VDC (logic side)	External 24VDC (field side)
<b>Discrete Combo I/O Modules</b>		
<a href="#">C0-16CDD1</a>	80	50
<a href="#">C0-16CDD2</a>	80	0
<a href="#">C0-08CDR</a>	80	0
<b>Analog Input Modules</b>		
<a href="#">C0-04AD-1</a>	20	65
<a href="#">C0-04AD-2</a>	23	65
<a href="#">C0-04RTD</a>	25	0
<a href="#">C0-04THM</a>	25	0
<b>Analog Output Modules</b>		
<a href="#">C0-04DA-1</a>	20	145
<a href="#">C0-04DA-2</a>	20	85
<b>Analog Combo I/O Modules</b>		
<a href="#">C0-4AD2DA-1</a>	25	75
<a href="#">C0-4AD2DA-2</a>	20	65
<b>C-more Micro-Graphic Panel</b>		
<b>Monochrome only</b>	90	0

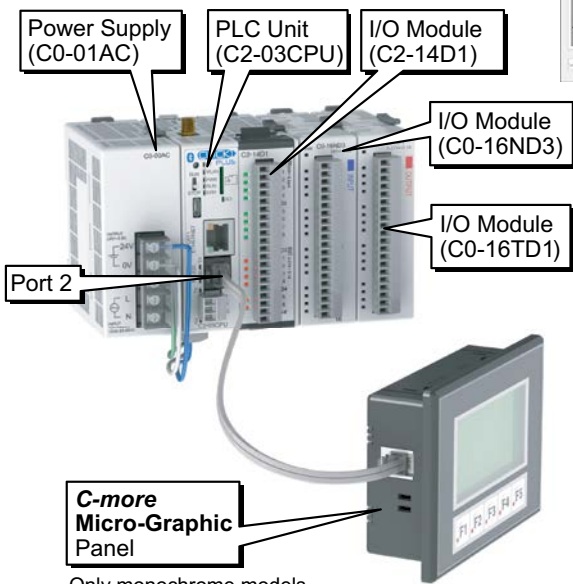
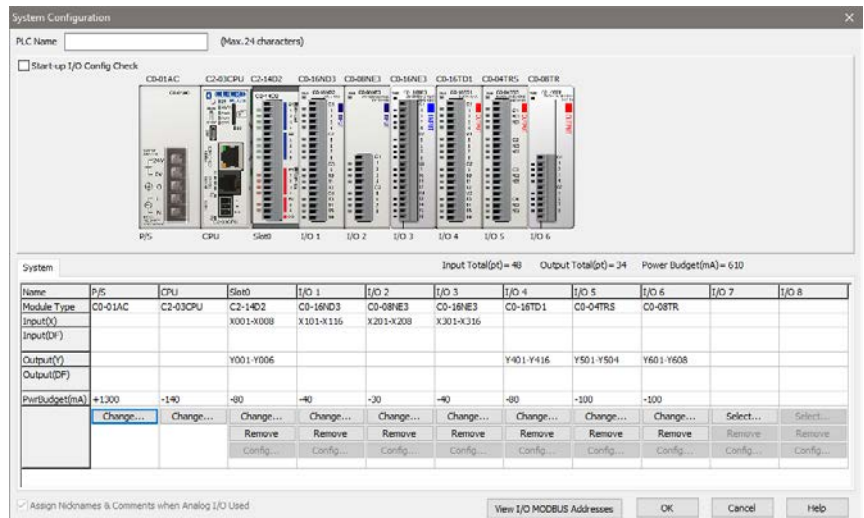

Only monochrome models can be powered from port 2.

### Power Budgeting Example

Current Consumption (mA) Example		
Part Number	Power Budget 24VDC (logic side)	External 24VDC (field side)
<a href="#">C2-03CPU</a>	130	0
<a href="#">C2-14D1</a>	50	60
<a href="#">C0-16ND3</a>	40	0
<a href="#">C0-16TD1</a>	80	100
<a href="#">C-more Micro</a>	90	0
<b>Total:</b>	<b>390</b>	<b>160 *</b>

\* Add in calculated load of connected I/O devices.

# CLICK Specifications

## CLICK PLC Hardware/Software Compatibility

CLICK PLCs require a minimum software version of v2.50 for the PID function. The table below shows the most recent software and hardware versions required for the High-Speed input operation capability to be accessible.

CLICK PLC Features Software Compatibility							
CPU Type	Part Number	Minimum CLICK Software Version					
		Hardware	High-Speed Inputs	EtherNet/IP	PID	DHCP	
<b>Basic</b>	<a href="#">C0-00DD1-D</a>	v1.00	N/A	N/A	N/A	N/A	
	<a href="#">C0-00DD2-D</a>						
	<a href="#">C0-00DR-D</a>						
	<a href="#">C0-00AR-D</a>						
<b>Standard</b>	<a href="#">C0-01DD1-D</a>	v1.20	N/A	N/A	N/A	N/A	
	<a href="#">C0-01DD2-D</a>						
	<a href="#">C0-01DR-D</a>						
	<a href="#">C0-01AR-D</a>						
<b>Analog</b>	<a href="#">C0-02DD1-D</a> (before SN 171208001)	v1.12	N/A	N/A	N/A	N/A	
	<a href="#">C0-02DD1-D</a> (after SN 171208001)	v2.10					
	<a href="#">C0-02DD2-D</a> (before SN 174018001)	v1.12					
	<a href="#">C0-02DD2-D</a> (after SN 174018001)	v2.10					
	<a href="#">C0-02DR-D</a> (before SN 173158001)	v1.12					
	<a href="#">C0-02DR-D</a> (after SN 173158001)	v2.10					
<b>Ethernet CPUs</b>	Ethernet CPUs require v2.40 for EtherNet/IP communications						
<b>Ethernet Basic</b>	<a href="#">C0-10DD1E-D</a>	v2.00	v2.30	v2.40	v2.50	v3.00	
	<a href="#">C0-10DD2E-D</a>						
	<a href="#">C0-10DRE-D</a>		N/A				
	<a href="#">C0-10ARE-D</a>						
<b>Ethernet Standard</b>	<a href="#">C0-11DD1E-D</a>	v2.00	v2.30	v2.40	v2.50	v3.00	
	<a href="#">C0-11DD2E-D</a>						
	<a href="#">C0-11DRE-D</a>		N/A				
	<a href="#">C0-11ARE-D</a>						
<b>Ethernet Analog</b>	<a href="#">C0-12DD1E-D</a>	v2.20	v2.30	v2.40	v2.50	v3.00	
	<a href="#">C0-12DD2E-D</a>						
	<a href="#">C0-12DRE-D</a>		N/A				
	<a href="#">C0-12ARE-D</a>						
	<a href="#">C0-12DD1E-1-D</a>		v2.30				
	<a href="#">C0-12DD2E-1-D</a>						
	<a href="#">C0-12DRE-1-D</a>		N/A				
	<a href="#">C0-12ARE-1-D</a>						
	<a href="#">C0-12DD1E-2-D</a>		v2.30				
	<a href="#">C0-12DD2E-2-D</a>						
	<a href="#">C0-12DRE-2-D</a>		N/A				
	<a href="#">C0-12ARE-2-D</a>						
<b>I/O Modules</b>	<a href="#">C0-08NE3</a>	v1.20	N/A	N/A	N/A	N/A	
	<a href="#">C0-16NE3</a>						
	<a href="#">C0-04AD-1</a>	v1.40					
	<a href="#">C0-04AD-2</a>						
	<a href="#">C0-04DA-1</a>						
	<a href="#">C0-04DA-2</a>						
	<a href="#">C0-4AD2DA-1</a>						
	<a href="#">C0-4AD2DA-2</a>						
	<a href="#">C0-04RTD</a>						
	<a href="#">C0-04THM</a>						
	<a href="#">C0-08CDR</a>						
	<a href="#">C0-16CDD1</a>						
	<a href="#">C0-16CDD2</a>						
	Other modules						v1.00