

# Bases

Please note: \$US prices shown  
For current \$AUD visit [www.directautomation.com.au](http://www.directautomation.com.au)

- P3-03B \$200.00
- P3-05B \$231.00
- P3-08B \$288.00
- P3-11B \$344.00

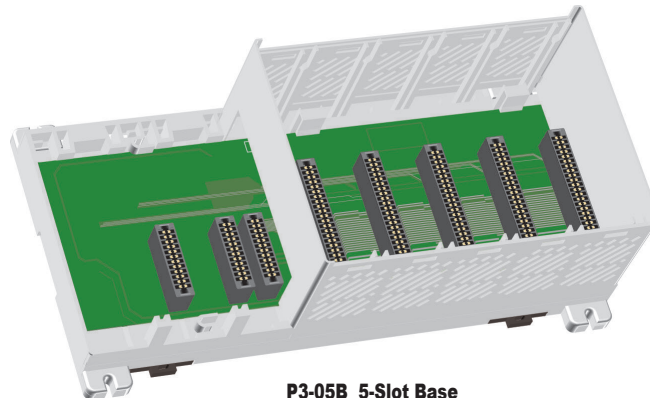

P3-05B 5-Slot Base

The P3-03B, P3-05B, P3-08B, and P3-11B are 3, 5, 8, and 11-slot, local, expansion, and remote I/O bases.

See Dimensions and Installation for base dimensions.

| Base Specifications              |  |
|----------------------------------|--|
| Input or Output Modules per Base | 3, 5, 8, or 11   |
| Power Supply Slots               | 1 (P3-01AC or P3-01DC)   |
| CPU Slots                        | 1 P3-550E/530, P3-RX and P3-EX compatible)   |
| Module Types Supported           | Discrete, analog and specialty   |
| Module Placement Restrictions    | None. Any I/O module may be installed in any I/O slot without power supply budget or module type restrictions. |
| I/O Module Hot Swap Support      | Yes. (All discrete and analog modules can be software enabled for Hot Swap operation)                          |
| Module Keying                    | Electronic to slot   |
| Maximum Number of Local Bases    | 5  |

## Base Configuration

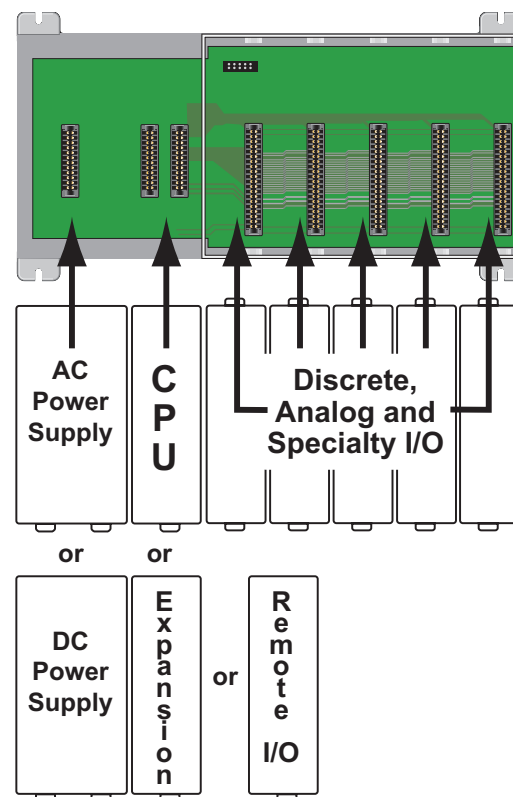

| General Specifications |  |
|------------------------|--|
| Operating Temperature  | 0°C– 60°C (32°F–140°F)   |
| Storage Temperature    | -20°C–70°C (-4°F–158°F)  |
| Humidity               | 5 to 95% (non-condensing)  |
| Environmental Air      | No corrosive gases permitted   |
| Vibration              | IEC60068-2-6 (Test Fc)   |
| Shock                  | IEC60068-2-27 (Test Ea)  |
| Heat Dissipation       | 2.5 W  |
| Weight                 | P3-03B: 1.365 lbs (21.8 oz.), 619g<br>P3-05B: 1.658 lbs (26.5 oz.), 752g<br>P3-08B: 2.158 lbs (34.5 oz.), 978g<br>P3-11B: 2.682 lbs (42.9 oz.), 1216g  |
| Agency Approvals       | UL508 file E157382, Canada & USA<br>UL1604 file E200031, Canada & USA<br>CE (EN61131-2*)<br>This equipment is suitable for use in Class 1, Division 2, Groups A, B, C and D or non-hazardous locations only. |

\*Meets EMC and Safety requirements. See the Declaration of Conformity for details.

# Dimensions and Installation

It is important to review and understand the installation requirements for your Productivity3000® system. Your knowledge of these requirements will help ensure that your system operates within its environmental and electrical limits.

## Plan for Safety

This catalog should never be used as a replacement for the product inserts and user manual. Each base, CPU, power supply, I/O module, remote slave, and expansion module comes with a product insert. You can purchase, download for free, or view online the Productivity3000 user manual (P3-USER-M). These documents, along with the software help files, contain important safety information that must be followed.

The system installation should comply with all appropriate electrical codes and standards.

## Enclosures

Your selection of a proper enclosure is important to ensure safe and proper operation of your Productivity3000 system. Applications for the Productivity3000 system vary and may require additional hardware considerations. The minimum considerations for enclosures include:

- Conformance to electrical standards
- Protection from the elements in an industrial environment
- Common ground reference
- Maintenance of specified ambient temperature
- Access to the equipment
- Security or restricted access
- Sufficient space for proper installation and maintenance of the equipment

## Mounting Position

Mount the bases horizontally, as shown in the illustration, to provide proper ventilation. Do not mount the bases vertically, upside down, or on a flat horizontal surface.

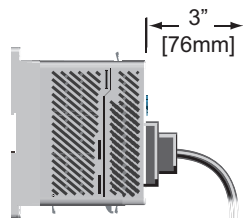
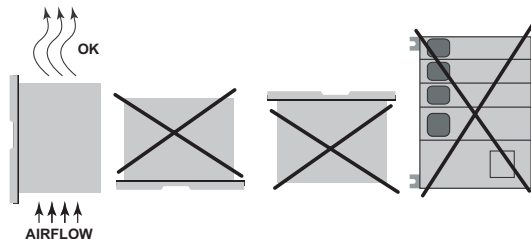
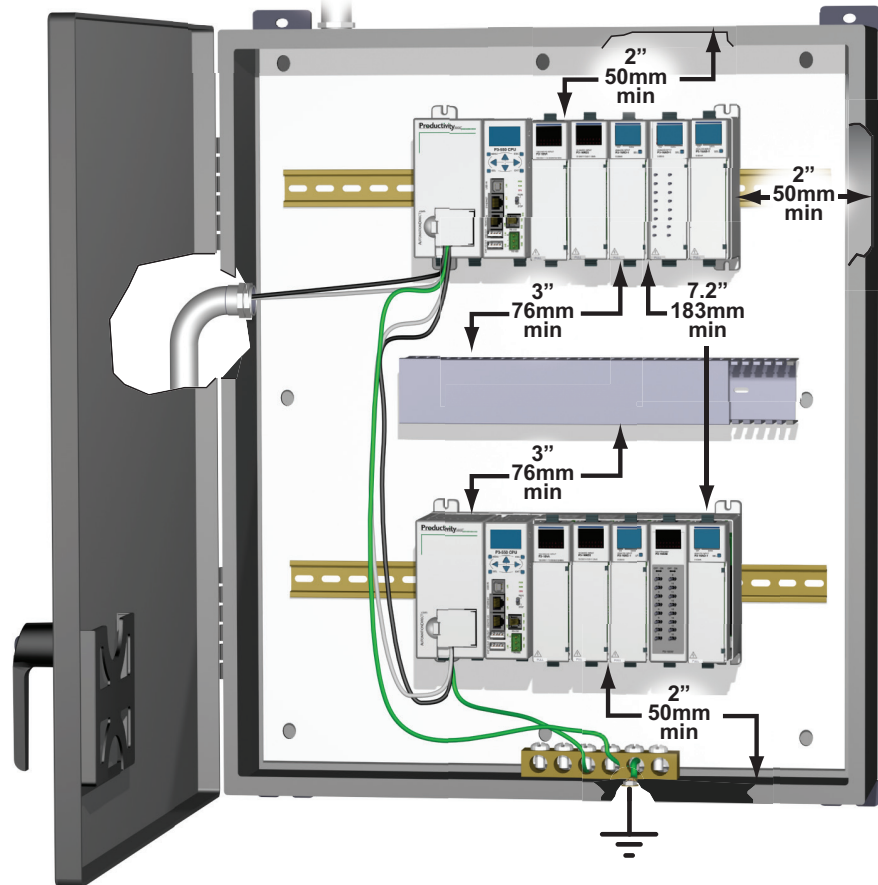

**NOTE:** Add 3 inches (76 mm) to mounting depth when using ZIPLink cable ZL-CBL40.

# Dimensions and Installation

## Mounting Clearances

Provide a minimum clearance of 2 inches (50mm) between the bases and all sides of the enclosure. Allow extra door clearance for operator panels and other door mounted items. There should be a minimum of 3 inches (76mm) clearance between the base and any wire duct, and a minimum of 7.2 inches (183mm) from base to base in a multiple base installation.

## Grounding

A good common ground reference (earth ground) is essential for proper operation of the Productivity3000® system. One side of all control circuits, power circuits and the ground lead must be properly connected to earth ground by either installing a ground rod in close proximity to the enclosure or by connecting to the incoming power system ground. There must be a single-point ground (i.e. copper bus bar) for all devices in the enclosure that require an earth ground.

## Temperature Considerations

The Productivity3000 system should be installed within the operating temperature specifications as listed in this document. If the temperature deviates above or below the specification, measures such as cooling or heating the enclosure should be taken to maintain the specification.

## Power Considerations

The Productivity3000 system is designed to be powered by 110/220 VAC or 24/48 VDC via one of the Productivity3000 power supplies. The Productivity3000 has achieved CE certification without requiring EMF/RFI line noise filters on the AC power supply. Please review the "EU Directives" document, located in the User Manual or at [www.automationdirect.com/productivity/p3000](http://www.automationdirect.com/productivity/p3000), for applications which require CE Compliance.

## Base Dimensions

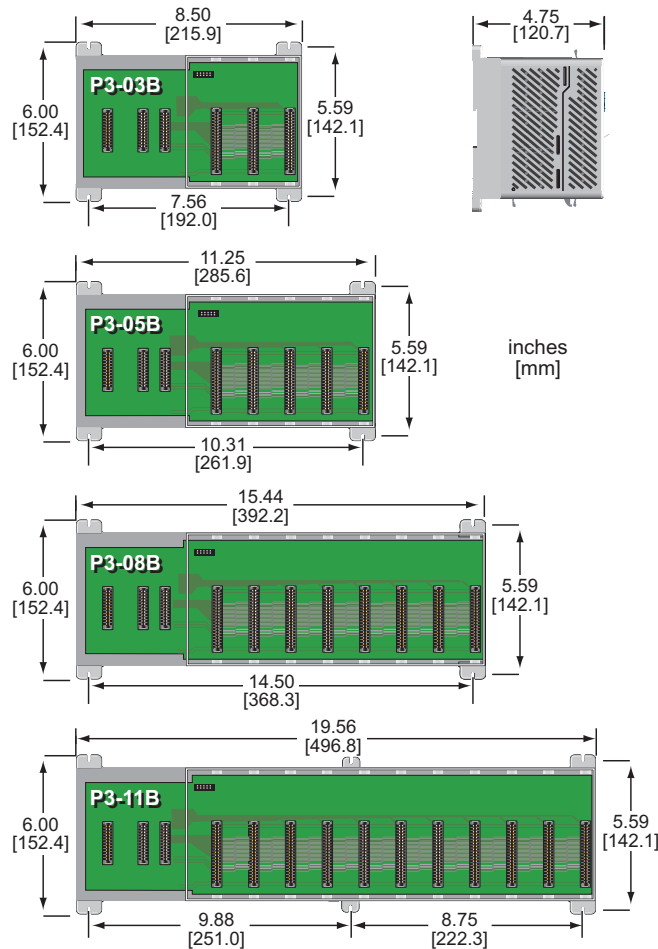

# Base Installation

## Using Mounting Rails

The Productivity3000® bases can be secured to the cabinet using mounting rails. You should use rails that conform to DIN EN standard 50 022. We offer a complete line of DIN rail, DINnectors and DIN rail mounted apparatus. These rails are approximately 35mm high, with a depth of 7.5 mm. If you mount the base on a rail, you should also consider using end brackets on each side of the base. The end brackets help keep the base from sliding horizontally along the rail. This helps minimize the possibility of accidentally pulling the wiring loose.

If you examine the bottom of the base, you'll notice retaining clips. To secure the base to a DIN rail, place the base onto the rail and gently push up on the retaining clips. The clips lock the base onto the rail.

To remove the base, pull down on the retaining clips, slightly lift up the base, and pull it away from the rail.

