

Power Supplies

Please note: \$US prices shown
For current \$AUD visit www.directautomation.com.au

P3-01AC \$227.00

There are two power supplies available; both provide isolated 24VDC, 5VDC, and 3.3 VDC to the Productivity3000 bases.

The P3-01AC input power supply requires power from an external 100–240 VAC source.

The P3-01DC input power supply requires power from an external 24–48 VDC source.

No Power Budgeting

No power budgeting is required with either power supply. Any combination of I/O modules may be installed in any slots without power budget considerations.



AC Input Power Supply

WARNING!: EXPLOSION HAZARD –
SUBSTITUTION OF COMPONENTS MAY IMPAIR
SUITABILITY FOR CLASS I, DIVISION 2.

IMPORTANT!



Hot-Swapping Information

Note: This device cannot be Hot Swapped.

P3-01AC User Specifications	
Input Voltage Range (Tolerance)	100 to 240 VAC (-15% / +10%)
Rated Operating Frequency	50 to 60 Hz with $\pm 5\%$ tolerance
Maximum Input Power	72W
Cold Start Inrush Current	12A 3ms
Maximum Inrush Current (Hot Start)	12A 3ms
Input Fuse Protection (Internal)	Micro fuse 250V, 2A, slow blow Non-replaceable
Efficiency	83%
Output	24VDC @ 1.4 A ($\pm 10\%$) 5VDC @ 2.1 A ($\pm 5\%$) 3.3 VDC @ 6.1 A ($\pm 5\%$)
Maximum Output Power	57W Combined
Heat Dissipation	17W
Isolated User 24VDC Output	None
Output Protection for Over Current, Over Voltage, and Over Temperature	Self resetting for all three voltage outputs to base
Under Input Voltage Lock-out	55–65 VAC
Over Input Voltage Lock-out	265–280 VAC
Input Transient Protection	Varistor, plus input choke and filter
Operating Design Life	10 years at full load at 40°C ambient and 5 years at 60°C ambient

P3-01AC General Specifications	
Operating Temperature	0°C–60°C (32°F–140°F),
Storage Temperature	-20°C–70°C (-4°F–158°F)
Humidity	5 to 95% (non-condensing)
Environmental Air	No corrosive gases permitted
Vibration	IEC60068-2-6 (Test Fc)
Shock	IEC60068-2-27 (Test Ea)
Enclosure Type	Open equipment
Voltage Withstand (dielectric)	1900 VDC applied for 2s
Insulation Resistance	>10M Ω @ 500VDC
Module Location	Power supply slot in any local, expansion, or remote base in a Productivity3000 [®] System.
Weight	345g (12.1 oz)
Agency Approvals	UL508 file E157382, Canada & USA UL1604 file E200031, Canada & USA CE (EN61131-2*) This equipment is suitable for use in Class 1, Division 2, Groups A, B, C and D or non-hazardous locations only.

*Meets EMC and Safety requirements. See the Declaration of Conformity for details.

Terminal Block Specifications	
Number of Positions	4 Screw Terminals
Pitch	0.3 inch (7.62 mm)
Wire Range	22–14 AWG (0.324 to 2.08 sq. mm) Solid Conductor 22–14 AWG (0.324 to 2.08 sq. mm) Stranded Conductor 3/64 inch (1.2 mm) insulation maximum
Screw Driver Width	1/4 inch (6.5mm) maximum
Screw Size	M3 size
Screw Torque	7–9 inch-pounds (0.882 - 1.02 N·m)

Power Supplies

Power Supply Installation

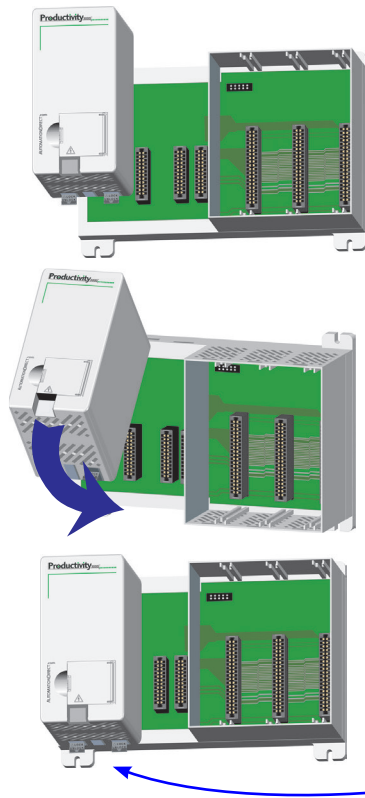

Step One:
Locate the left most socket in the base.

Step Two:
Insert the Power Supply at a 45° angle into the notch located at the top of the base and rotate down until seated in socket.

Step Three:
Snap the two retaining tabs into the locked position.

WARNING!: EXPLOSION HAZARD – DO NOT CONNECT OR DISCONNECT CONNECTORS OR OPERATE SWITCHES WHILE CIRCUIT IS LIVE UNLESS THE AREA IS KNOWN TO BE NON-HAZARDOUS. DO NOT HOT SWAP.

Power Connections

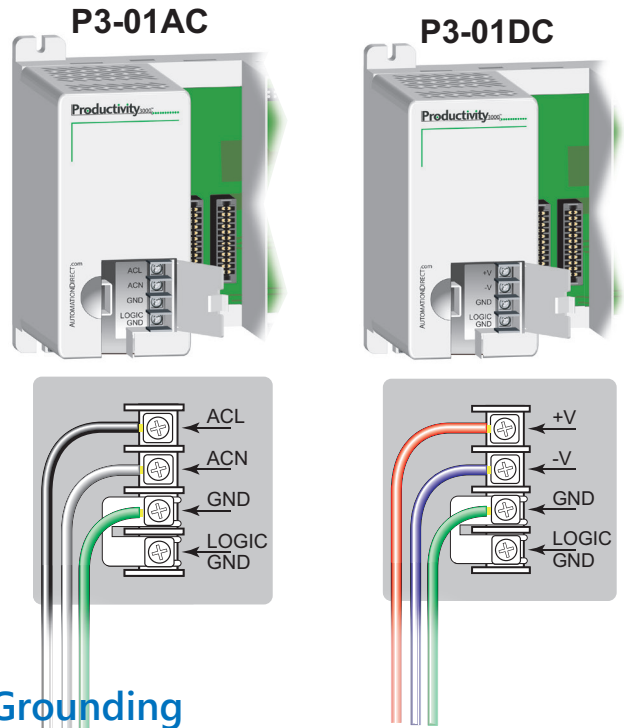

Grounding

A good common ground reference (earth ground) is essential for proper operation of the Productivity3000® system. One side of all control circuits, power circuits and the ground lead must be properly connected to earth ground by either installing a ground rod in close proximity to the enclosure or by connecting to the incoming power system ground. There must be a single-point ground (i.e. copper bus bar) for all devices in the enclosure that require an earth ground.

Dimensions and Installation

It is important to review and understand the installation requirements for your Productivity3000® system. Your knowledge of these requirements will help ensure that your system operates within its environmental and electrical limits.

Plan for Safety

This catalog should never be used as a replacement for the product inserts and user manual. Each base, CPU, power supply, I/O module, remote slave, and expansion module comes with a product insert. You can purchase, download for free, or view online the Productivity3000 user manual (P3-USER-M). These documents, along with the software help files, contain important safety information that must be followed.

The system installation should comply with all appropriate electrical codes and standards.

Enclosures

Your selection of a proper enclosure is important to ensure safe and proper operation of your Productivity3000 system. Applications for the Productivity3000 system vary and may require additional hardware considerations. The minimum considerations for enclosures include:

- Conformance to electrical standards
- Protection from the elements in an industrial environment
- Common ground reference
- Maintenance of specified ambient temperature
- Access to the equipment
- Security or restricted access
- Sufficient space for proper installation and maintenance of the equipment

Mounting Position

Mount the bases horizontally, as shown in the illustration, to provide proper ventilation. Do not mount the bases vertically, upside down, or on a flat horizontal surface.

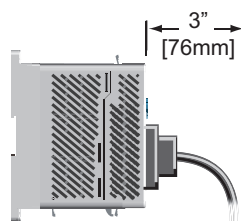
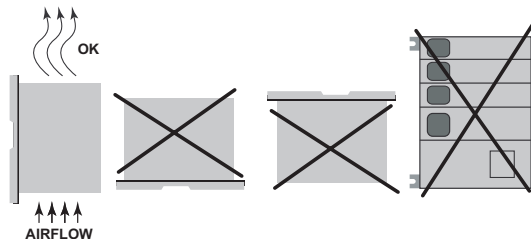
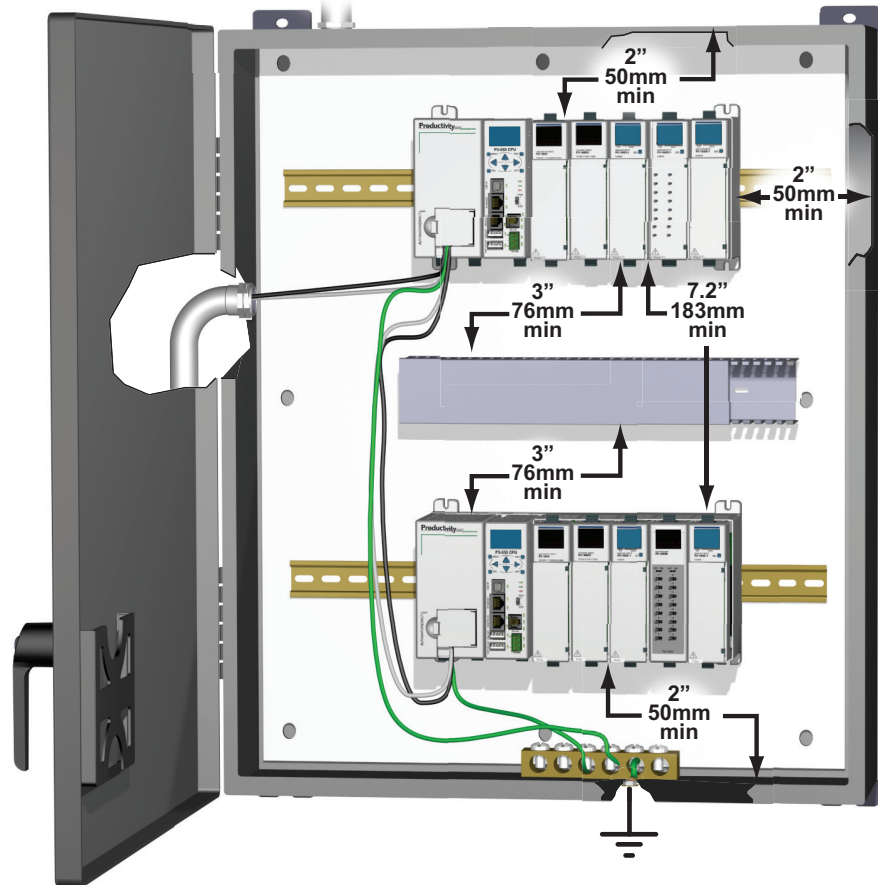

NOTE: Add 3 inches (76 mm) to mounting depth when using ZIPLink cable ZL-CBL40.

Dimensions and Installation

Mounting Clearances

Provide a minimum clearance of 2 inches (50mm) between the bases and all sides of the enclosure. Allow extra door clearance for operator panels and other door mounted items. There should be a minimum of 3 inches (76mm) clearance between the base and any wire duct, and a minimum of 7.2 inches (183mm) from base to base in a multiple base installation.

Grounding

A good common ground reference (earth ground) is essential for proper operation of the Productivity3000® system. One side of all control circuits, power circuits and the ground lead must be properly connected to earth ground by either installing a ground rod in close proximity to the enclosure or by connecting to the incoming power system ground. There must be a single-point ground (i.e. copper bus bar) for all devices in the enclosure that require an earth ground.

Temperature Considerations

The Productivity3000 system should be installed within the operating temperature specifications as listed in this document. If the temperature deviates above or below the specification, measures such as cooling or heating the enclosure should be taken to maintain the specification.

Power Considerations

The Productivity3000 system is designed to be powered by 110/220 VAC or 24/48 VDC via one of the Productivity3000 power supplies. The Productivity3000 has achieved CE certification without requiring EMF/RFI line noise filters on the AC power supply. Please review the "EU Directives" document, located in the User Manual or at www.automationdirect.com/productivity/p3000, for applications which require CE Compliance.

Base Dimensions

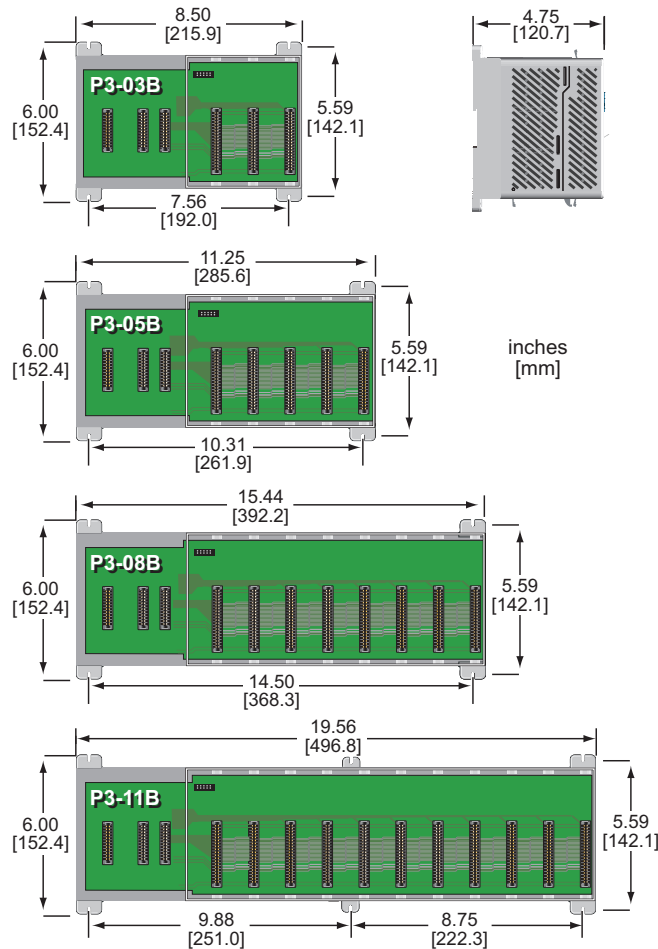

Base Installation

Using Mounting Rails

The Productivity3000® bases can be secured to the cabinet using mounting rails. You should use rails that conform to DIN EN standard 50 022. We offer a complete line of DIN rail, DINnectors and DIN rail mounted apparatus. These rails are approximately 35mm high, with a depth of 7.5 mm. If you mount the base on a rail, you should also consider using end brackets on each side of the base. The end brackets help keep the base from sliding horizontally along the rail. This helps minimize the possibility of accidentally pulling the wiring loose.

If you examine the bottom of the base, you'll notice retaining clips. To secure the base to a DIN rail, place the base onto the rail and gently push up on the retaining clips. The clips lock the base onto the rail.

To remove the base, pull down on the retaining clips, slightly lift up the base, and pull it away from the rail.

