

# Which switch is right for you?

## Compact Fusible Switches



**Gladiator**<sup>®</sup>  
from AutomationDirect

### Overview

AutomationDirect Gladiator compact fusible switches provide open fuse indication for faster troubleshooting and reduced downtime. Gladiator switches have Lockout / Tagout capability and finger safe construction to promote safe workplace practices by preventing contact with live components. Positive visible circuit isolation via the disconnect switch makes it easy to view status. Each switch is 35mm DIN rail mountable for ease of installation and requires no tools. Taking up only 1/3 the space of a molded circuit breaker and 2/3 the space of a traditional fusible switch, Gladiator fusible switches save space in your panel.

### Features and Benefits

- Class CC and Midget fuse options
- 200kA Short-Circuit Current Rating (SCCR) with Class CC fuses meets high assembly SCCR and reduced personal protective equipment (PPE) requirements
- Full voltage rating up to 600 VAC allows installation flexibility versus slash-rated devices at 480/277 VAC
- Horsepower rated for protecting motor circuits with Class CC units
- UL 98 disconnect rated for protection of branch circuits
- 35 mm DIN-rail mountable, utilizing spring clip

### Applications

#### Feeder and Branch Circuit Protection

- Service Entrance or Main Panel Disconnect (UL 98 Class CC)
- Resistive Heating and Lighting Circuit
- Fusible Isolation Switch
- Convenience receptacle circuits (internal / external)
- Motor control circuits
- Load circuits leaving the equipment (external)
- HACR Equipment (Heating Air Conditioning, Refrigeration)
- Computers
- Power supplies

### Listings

#### UL Class CC fuse version

- UL Listed under UL 98 File E339079, Guide WHTY
- cULus 22.2, No. 4-04 File 339079, Guide WHTY7
- CE Compliant
- RoHS

#### UL Class Midget fuse version

- UL Listed under UL 508 File E222847, Guide NRNT
- cULus 22.2, No. 14-05
- CE Compliant
- RoHS

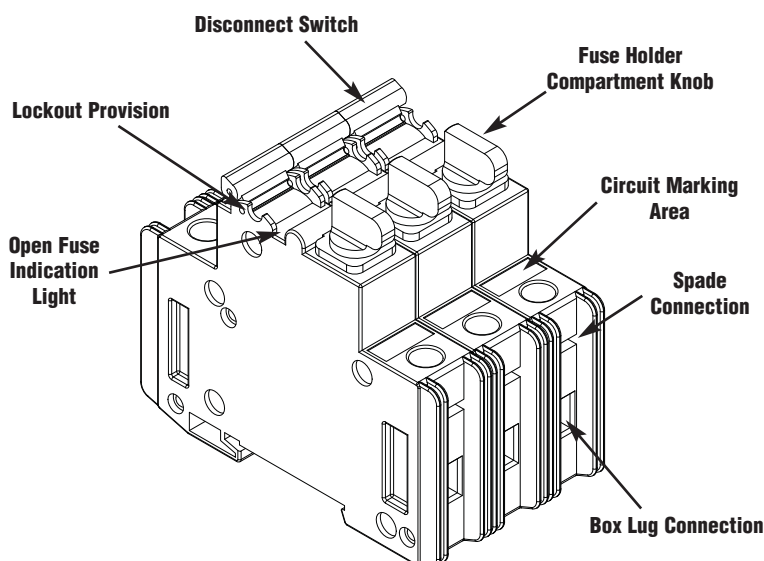

# Gladiator<sup>®</sup> Compact Fusible Switches

from AutomationDirect

## AC and DC Compact Fusible Switches



Single-Pole



Two-Pole



Three-Pole



DC Single-Pole

Compact Fusible Switch Specifications - AC Switches								
Part Number	Poles	Max Fuse Ampacity	Voltage Range	Fuse Type	SCCR	Agency Approvals	HP Ratings	Price
<b>CFS-1PCC30</b>	1	30A	90 - 600 VAC	Class CC	200 kA	UL 98 Listed cULus 22.2 No. 4-04	0.5 HP @ 120 VAC	<--->
<b>CFS-1PM30</b>			90 - 240 VAC*	UL Midget	10 kA*	UL 508 Listed CULus 22.2 No.14-05	n/a	<--->
<b>CFS-2PCC30</b>	2		90 - 600 VAC	Class CC	200 kA	UL 98 Listed cULus 22.2 No. 4-04	2.0 HP @ 240 VAC	<--->
<b>CFS-2PM30</b>			90 - 240 VAC*	UL Midget	10 kA*	UL 508 Listed CULus 22.2 No.14-05	n/a	<--->
<b>CFS-3PCC30</b>	3		90 - 600 VAC	Class CC	200 kA	UL 98 Listed cULus 22.2 No. 4-04	3.0 HP @ 240 VAC 5.0 HP @ 480 VAC 7.5 HP @ 600 VAC	<--->
<b>CFS-3PM30</b>			90 - 240 VAC*	UL Midget	10 kA*	UL 508 Listed CULus 22.2 No.14-05	n/a	<--->

*Note: The minimum enclosure size is 14 in. x 12 in. x 6 in. Minimum spacings are 2 inches over surface, 1 inch through air.  
\* Rating may be lower depending upon installed fuse. Refer to fuse specifications.*

Compact Fusible Switch Specifications - DC Switches							
Part Number	Poles	Max Fuse Ampacity	Voltage Range	Fuse Type	SCCR	Agency Approvals	Price
<b>CFS-1PCC30-DC</b>	1	30A	12 - 80 VDC*	Class CC	200 kA*	UL 98 Listed cULus 22.2 No. 4-04	<--->
<b>CFS-1PM30-DC</b>			12 - 80 VDC*	UL Midget	10 kA*	UL 508 Listed CULus 22.2 No.14-05	<--->

*\* Rating may be lower depending upon installed fuse. Refer to fuse specifications.*

General Specifications		
<b>Construction</b>	RoHS compliant, IP20 compliant with 10 AWG or larger wire	
<b>Operating Temperature</b>	-20 °C to 75 °C (-4 °F to 167 °F)	
<b>Flammability Rating</b>	UL 94V0	
<b>Frequency</b>	50/60 Hz	
<b>Padlockable</b>	Yes [4mm (0.16 in) shank]	
<b>Local Indication</b>	Yes	
<b>Mounting</b>	35 mm DIN Rail	
<b>Weight</b>	One-Pole	0.22 lbs. (100g)
	Two-Pole	0.43 lbs. (195g)
	Three-Pole	0.65 lbs. (295g)

Wire Range		
Number of Wires	Wire Size	
One Wire	4 AWG	21 mm <sup>2</sup>
Two Wires	18 to 6 AWG	0.75 to 13 mm <sup>2</sup>

*Note: The use of wire ferrules or crimping terminals is not recommended in box lugs.*

Tightening Torque		
Cable Size	Tightening Torque	
18 - 10 AWG	2.3 Nm	20 lb-in
8 - 4 AWG	4.0 Nm	35 lb-in

Recommended Fuse Types			
AC Voltage Class CC			
Edison	Bussmann	Gould	Littlefuse
HCLR	KTK-R	ATMR	KLKR
HCTR	FNQ-R	ATQR	KLDR
EDSS	LP-CC	ATDR	CCMR
AC Voltage Class Midget			
Edison	Bussmann	Gould	Littlefuse
MCL	KTK	ATM	KLK
MOL	BAF / BAN	OTM	BLF
MEQ	FNQ	ATQ	FLQ
MEN	FNM	TRM	FLM
DC Voltage Class CC			
Edison	Bussmann	Gould	Littlefuse
EDCC	LP-CC	ATDR	CCMR
DC Voltage Class Midget			
Edison	Bussmann	Gould	Littlefuse
N/A	KLM	ATM	KLKD
	DCM		



# Gladiator<sup>®</sup> Compact Fusible Switches

from AutomationDirect

## Motor Sizing - Compact Fusible Switches

Motor Sizing Chart						
Voltage	Motor HP	Motor Full Load Amps	Fuse Type	Minimum Fuse Amperage	Code Max Fuse Amperage	Heavy Start Fuse Amperage
115 VAC - 1 Phase	1/6	4.4	EDCC	9	15	15
	1/4	5.8		12	20	20
	1/3	7.2		15	25	25
	1/2	9.8		30	30	30
230 VAC - 1 Phase	1/6	2.2	EDCC	4.5	10	10
	1/4	2.9		6	10	10
	1/3	3.6		7	15	15
	1/2	4.9		10	15	15
	3/4	6.9		15	25	25
	1	8.0		25	25	30
	1-1/2	10.0		30	30	30
200 VAC - 3 Phase	1/2	2.5	EDCC	5	10	10
	3/4	3.7		7.5	15	15
	1	4.8		10	15	15
	1-1/2	6.9		15	25	25
	2	7.8		25	25	30
208 VAC - 3 Phase	1/2	2.4	EDCC	5	10	10
	3/4	3.5		7	15	15
	1	4.6		10	15	15
	1-1/2	6.6		15	20	25
	2	7.5		15	25	30
230 VAC - 3 Phase	1/2	2.2	EDCC	4.5	10	10
	3/4	3.2		7	10	12
	1	4.2		9	15	15
	1-1/2	6.0		12	20	20
	2	6.8		15	25	25
	3	9.6		30	30	30
460 VAC - 3 Phase	1/2	1.1	EDCC	2.25	6	6
	3/4	1.6		3.2	6	6.25
	1	2.1		4.5	10	10
	1-1/2	3.0		6	10	12
	2	3.4		7	15	15
	3	4.8		10	15	15
	5	7.6		25	25	30
575 VAC - 3 Phase	1/2	0.9	EDCC	1.8	3	3.5
	3/4	1.3		2.8	6	6
	1	1.7		3.5	6	6.25
	1-1/2	2.4		5	10	10
	2	2.7		5.6	10	10
	3	3.9		8	15	15
	5	6.1		15	20	20
	7-1/2	9.0		30	30	30

**Note: NEMA motors only (no IEC or Design B Energy Efficient). Minimum size if no more than 1 start / hour. Use Code Max Fuse Amperage in low to moderate reverse / jog / plug applications. Use Heavy Start Fuse Amperage only if Code Max does not allow motor start up. For high reverse / jog / plug applications or larger horsepower motors, Class J fuses are recommended. (Refer to time-current curves for specific applications.) Per NEC 430.52**

Company Information

Systems Overview

Programmable Controllers

Field I/O

Software

C-more & other HMI

Drives

Soft Starters

Motors & Gearbox

Steppers/ Servos

Motor Controls

Proximity Sensors

Photo Sensors

Limit Switches

Encoders

Current Sensors

Pressure Sensors

Temperature Sensors

Pushbuttons/ Lights

Process

Relays/ Timers

Comm.

Terminal Blocks & Wiring

Power

Circuit Protection

Enclosures

Tools

Pneumatics

Safety

Appendix

Product Index

Part # Index

# Gladiator<sup>®</sup> Compact Fusible Switches

from AutomationDirect

## Compact Fusible Switches Dimensions

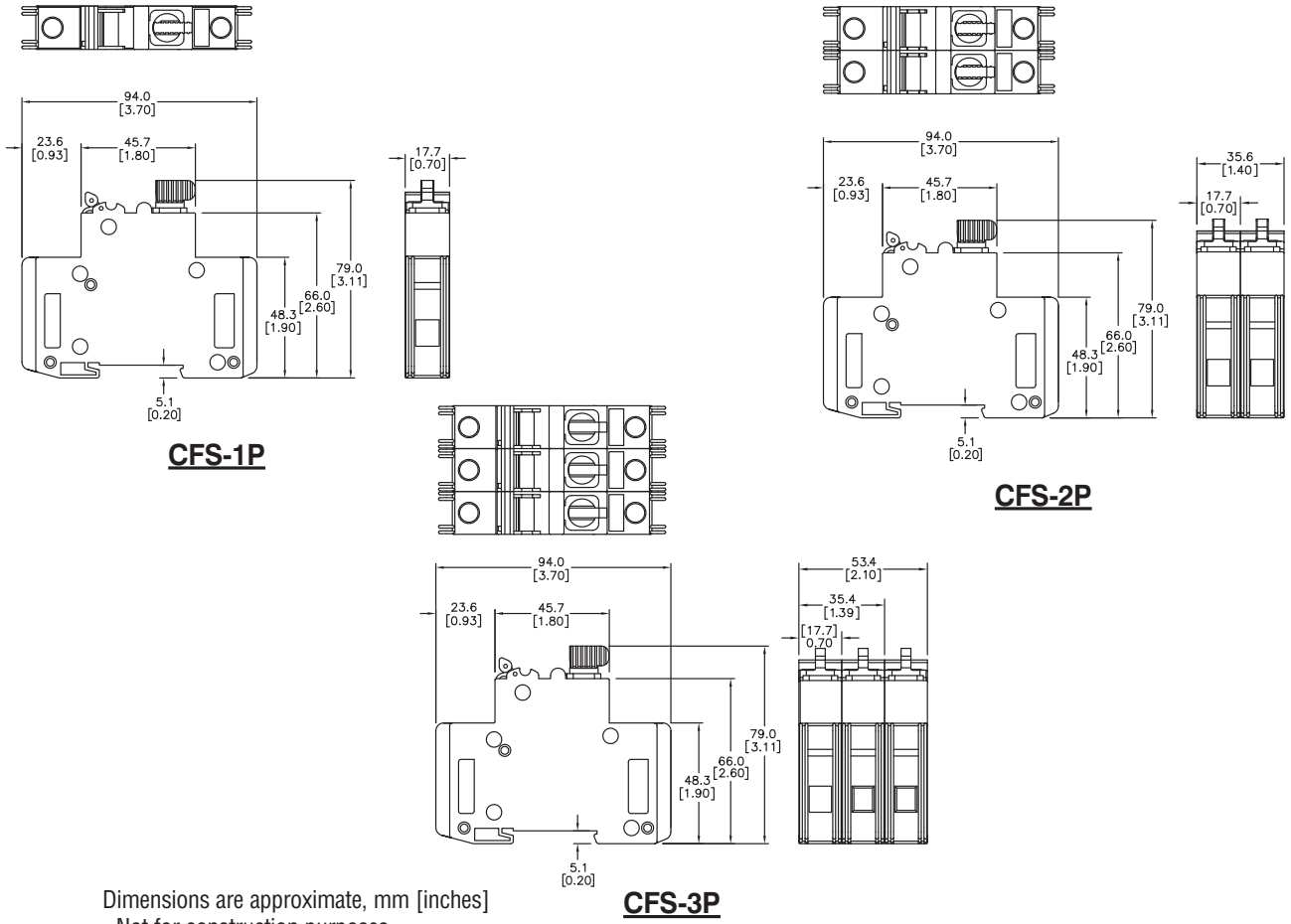

Dimensions are approximate, mm [inches]  
- Not for construction purposes

## Replacing Fuses

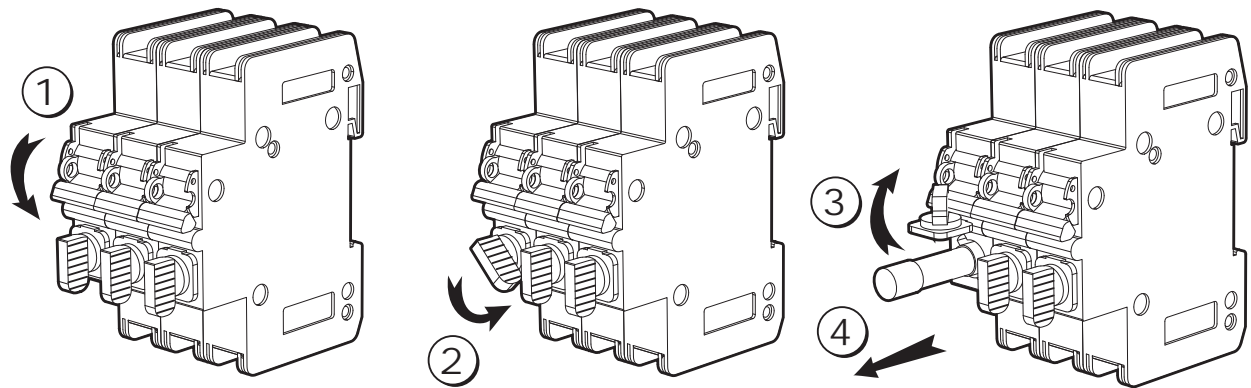

### Steps:

1. Turn Switch Off.
2. Turn fuse holder compartment knob counterclockwise.
3. Rotate fuse holder compartment knob up.
4. \*Remove fuse and replace with appropriate type CC or Midget fuse.

**\*Note: Insert replacement CC fuse with rejection feature (tip) in first.**

# Gladiator<sup>®</sup> Compact Fusible Switches

from AutomationDirect

## Auxiliary Contact

N.O. + N.C. contact output to indicate the status of the switching mechanism on the Gladiator switch.  
Mounts on the right side of the switch.



**CFS-AUX**

General Specifications - CFS-AUX							
Part Number	Description	Rated Ampacity	Rated Voltage	Flamibility Rating	Agency Approvals	Weight	Price
<b>CFS-AUX</b>	Auxiliary contact switch 1 NO + 1 NC	5A	240 VAC	UL 94V0	UL 98 Recognized and cURus 22.2 No. 4-04, IEC 60947-5-1 AC15	0.11 lbs. (50g)	<--->

## Auxiliary Contact Dimensions

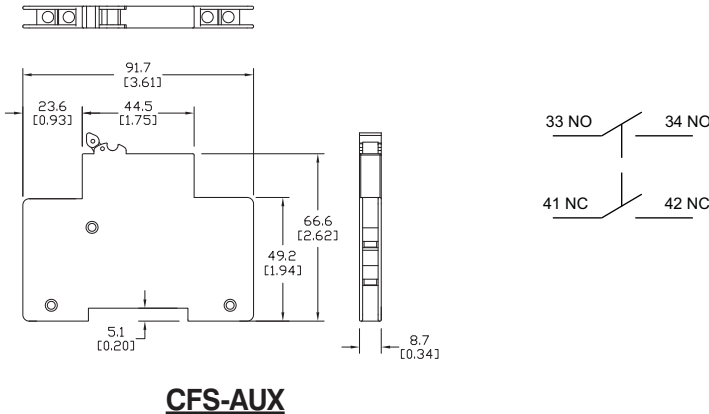

**CFS-AUX**