

# Analog Input Module

## P3-16AD-1



### Current Analog Input

The P3-16AD-1 Current Analog Input Module provides sixteen channels for receiving current sinking 0 to 20mA input signals.

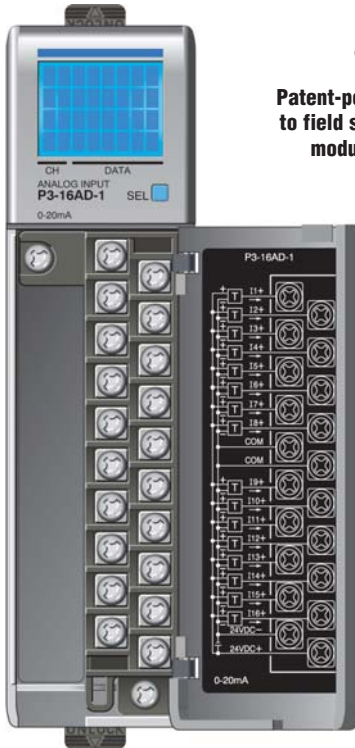

Patent-pending LCD gives access to field signal values, as well as module and signal faults.

Terminal block sold separately; terminal block cover included with module.

### Removable Terminal Block Specifications

Description	Part No. P3-RTB; 20 screw terminals
Wire Range	22-14 AWG (0.324 to 2.08 sq. mm) Solid / stranded conductor 3/64 in. (1.2 mm) insulation maximum "USE COPPER CONDUCTORS , 60°C" or equivalent.
Screw Driver Width	1/4 inch (6.5 mm) maximum
Screw Size	M3 size
Screw Torque	Field terminals – 7 - 9 in./lb (.0882 - 1.02 Nm) Self-jacking screws – 2.7 - 3.6 in./lb (0.3 - 0.4 Nm). Do not overtighten screws when installing terminal block.

We recommend using prewired **ZIPLink** cables and connection modules. See "Wiring Systems".

Terminal block cover included. If you wish to hand-wire your module, a removable terminal block is sold separately. Order part number P3-RTB.



### Input Specifications

Input Channels	16 sinking
Module Signal Input Range	0 - 20mA
Signal Resolution	16 bit
Resolution Value of LSB (least significant bit)	0-20mA = 305µA per count (1 LSB = 1 count)
Data Range	0-65535 counts
Input Type	Single-ended (1 common)
Maximum Continuous Overload	±31mA
Input Impedance	250 Ω ±0.1% ¼W
Filter Characteristics	Low Pass, -3dB @ 100Hz
Sample Duration Time	7 ms per channel (does not include ladder scan time)
All Channel Update Rate	112 ms
Open Circuit Detection Time	Zero reading within 1s
Conversion Method	Successive approximation
Accuracy vs. Temperature	±25PPM / °C maximum
Maximum Inaccuracy	0.1% of range (including temperature drift)
Linearity Error (end to end)	±10 LSB maximum (±0.015% of range) Monotonic with no missing codes
Input Stability and Repeatability	±10 LSB
Full Scale Calibration Error (not including offset)	±10 LSB maximum (±0.015% of range)
Offset Calibration Error	±10 LSB maximum
Max Crosstalk	-76 dB, ±10 LSB
Recommended Fuse (external)	Edison S500-32-R, .032A fuse
External DC Power Required	24VDC (-20% / + 25%) 20mA

### General Specifications

Operating Temperature	0° to 60°C (32° to 140°F),
Storage Temperature	-20° to 70°C (-4° to 158°F)
Humidity	5 to 95% (non-condensing)
Environmental Air	No corrosive gases permitted
Vibration	MIL STD 810C 514.2
Shock	MIL STD 810C 516.2
Field to Logic Side Isolation	1800VAC applied for 1 second
Insulation Resistance	>10MΩ @ 500 VDC
Heat Dissipation	2.1 W
Enclosure Type	Open Equipment
Agency Approvals	UL508 file E157382, Canada & USA UL1604 file E200031, Canada & USA CE (EN61131-2*) This equipment is suitable for use in Class 1, Division 2, Groups A, B, C and D or non-hazardous locations only.
Module Keying to Backplane	Electronic
Module Location	Any I/O slot in any local, expansion, or remote base in a Productivity3000 System.
Field Wiring	Removable terminal block (not included). Use ZIPLink wiring system or optional terminal block. See "Wiring I/O Modules".
EU Directive	See the "EU Directive" topic in the Productivity3000 Help File. Information can also be obtained at: <a href="http://www.productivitypac.com">www.productivitypac.com</a>
Terminal Type (not included)	20-position removable terminal block
Weight	105g (3.73 oz)

\*Meets EMC and Safety requirements. See the Declaration of Conformity for details.

**WARNING:** Explosion hazard – Substitution of components may impair suitability for Class I, Division 2.

# Analog Input Module

## P3-16AD-1 (Cont'd)

### Wiring Diagrams

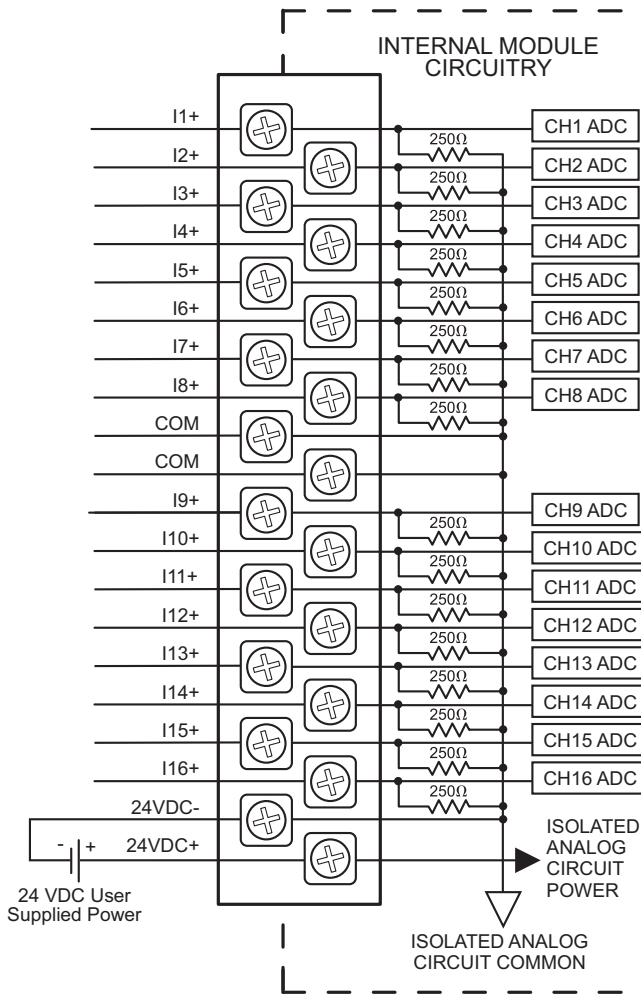

### Current Input Circuits

An Edison S500-32-R 0.032A fast-acting fuse is recommended for current loops.

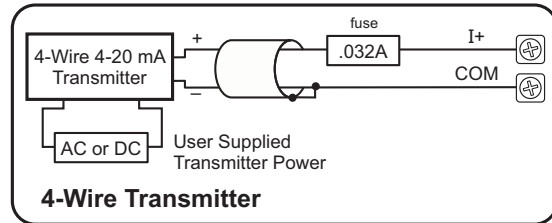
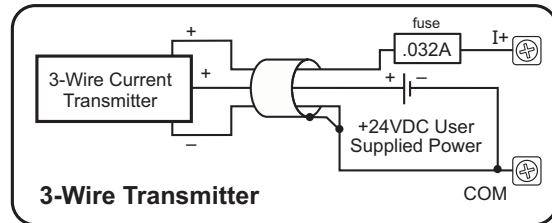
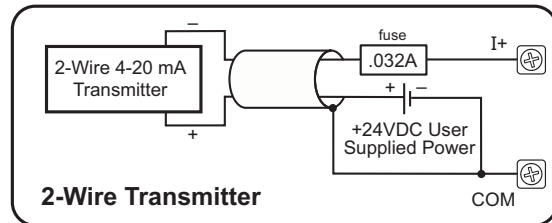

Note: Do not connect both ends of shield.

## Specify your ZIPLink system

Use the Compatibility Matrix table below.



<b>Step 1</b>	Locate the I/O module part number.
<b>Step 2</b>	Locate Connector Module Type. (Feedthrough Module, Fuse Module, etc...)
<b>Step 3</b>	Select the cable length by replacing the # symbol with: Blank = 0.5m, -1 = 1.0m, -2 = 2.0m <sup>1</sup>
<sup>1</sup> Note: Cable part number denotes compatibility between Connector Module and I/O Modules.	

Productivity3000 ZIPLink Wiring System Compatibility Matrix								
Step 2: Connector Module Type		Feedthrough Modules		Fuse Modules		Relay Module	Sensor Input Mod.	Pigtail Cable
Step 1: I/O Module	Number of Terminals	ZL-RTB20	ZL-RTB40	ZL-RFU20	ZL-RFU40	ZL-RRL16-24	ZL-LTB16-24	
Step 3: Cables								
<b>Inputs</b>								
<b>P3-08NAS</b>	20	ZL-P3-CBL20#						ZL-P3-CBL20-#P
<b>P3-08ND3S</b>	20	ZL-P3-CBL20#						ZL-P3-CBL20-#P
<b>P3-16NA</b>	20	ZL-P3-CBL20L#						ZL-P3-CBL20-#P
<b>P3-16ND3</b>	20	ZL-P3-CBL20L#						ZL-P3-CBL20-#P
<b>P3-32ND3</b>	40		ZL-CBL40#				ZL-P3-CBL40#	
<b>P3-64ND3*</b>	40		ZL-CBL40#				ZL-P3-CBL40#	
<b>Outputs</b>								
<b>P3-08TAS</b>	20	ZL-P3-CBL20#						ZL-P3-CBL20-#P
<b>P3-08TD1S</b>	20	ZL-P3-CBL20L#						ZL-P3-CBL20-#P
<b>P3-08TD2S</b>	20	ZL-P3-CBL20L#						ZL-P3-CBL20-#P
<b>P3-08TRS</b>	20	ZL-P3-CBL20#						ZL-P3-CBL20-#P
<b>P3-16TA</b>	20	ZL-P3-CBL20#		ZL-P3-CBL20L#				ZL-P3-CBL20-#P
<b>P3-16TD1</b>	20	ZL-P3-CBL20#		ZL-P3-CBL20#		ZL-P3-CBL20#		ZL-P3-CBL20-#P
<b>P3-16TD2</b>	20	ZL-P3-CBL20#		ZL-P3-CBL20#				ZL-P3-CBL20-#P
<b>P3-16TR</b>	20	ZL-P3-CBL20#		ZL-P3-CBL20#				ZL-P3-CBL20-#P
<b>P3-08TRS-1***</b>	20	ZL-P3-CBL20#						ZL-P3-CBL20-#P
<b>P3-32TD1</b>	40		ZL-CBL40#		ZL-CBL40#			
<b>P3-32TD2</b>	40		ZL-CBL40#		ZL-CBL40#			
<b>P3-64TD1*</b>	40		ZL-CBL40#		ZL-CBL40#			
<b>P3-64TD2*</b>	40		ZL-CBL40#		ZL-CBL40#			
<b>Analog In</b>								
<b>P3-04ADS</b>	20	ZL-P3-CBL20L#						ZL-P3-CBL20-#P
<b>P3-08AD</b>	20	ZL-P3-CBL20L#						ZL-P3-CBL20-#P
<b>P3-16AD-1</b>	20	ZL-P3-CBL20L#						ZL-P3-CBL20-#P
<b>P3-16AD-2</b>	20	ZL-P3-CBL20L#						ZL-P3-CBL20-#P
<b>P3-08RTD**</b>	Matched Only							
<b>P3-08THM**</b>	T/C Wire Only							
<b>Analog Out</b>								
<b>P3-04DA</b>	20	ZL-P3-CBL20L#						ZL-P3-CBL20-#P
<b>P3-08DA-1</b>	20	ZL-P3-CBL20L#						ZL-P3-CBL20-#P
<b>P3-08DA-2</b>	20	ZL-P3-CBL20L#						ZL-P3-CBL20-#P
<b>P3-06DAS-1</b>	20	ZL-P3-CBL20L#						ZL-P3-CBL20-#P
<b>P3-06DAS-2</b>	20	ZL-P3-CBL20L#						ZL-P3-CBL20-#P
<b>P3-16DA-1</b>	20	ZL-P3-CBL20L#						ZL-P3-CBL20-#P
<b>P3-16DA-2</b>	20	ZL-P3-CBL20L#						ZL-P3-CBL20-#P
<b>Analog Combo</b>								
<b>P3-8AD4DA-1</b>	20	ZL-P3-CBL20L#						ZL-P3-CBL20-#P
<b>P3-8AD4DA-2</b>	20	ZL-P3-CBL20L#						ZL-P3-CBL20-#P

\*The P3-64ND3, P3-64TD1, and P3-64TD2 modules have two 32-point connectors and require 2 ZIPLink cables and 2 ZIPLink connector modules.

\*\*These modules are not supported by the ZIPLink wiring system. Removable terminal block P3-RTB included.

\*\*\*The P3-08TRS-1 output module is derated, not to exceed 2A per point maximum when used with the ZIPLink wiring system.

# I/O Modules

A variety of discrete and analog I/O modules are available for use in local, expansion, and remote I/O bases. Specifications for each module are on the following pages.

A filler module is available for unused I/O module slots (part number P3-FILL).



## Discrete Input Modules

Productivity3000 Discrete Input Modules			
Part Number	Number of Inputs	Description	Price
P3-16SIM	16	Input Simulator Module	<--->
P3-08ND3S	8	Isolated Sinking/Sourcing DC Input	<--->
P3-16ND3	16	Sinking/Sourcing DC Input	<--->
P3-32ND3*	32	Sinking/Sourcing DC Input	<--->
P3-64ND3*	64	Sinking/Sourcing DC Input	<--->
P3-08NAS	8	Isolated AC Input	<--->
P3-16NA	16	AC Input	<--->

\*ZIPLink required.

## Analog I/O Modules

Productivity3000 Analog Input Modules			
Part Number	Number of Channels	Description	Price
P3-04ADS	4	Isolated Analog Input	<--->
P3-08AD	8	Analog Input	<--->
P3-16AD-1	16	Analog Input (Current)	<--->
P3-16AD-2	16	Analog Input (Voltage)	<--->
P3-08RTD	8	Analog RTD Input	<--->
P3-08THM	8	Analog Thermocouple Input	<--->

Productivity3000 Analog Output Modules			
Part Number	Number of Channels	Description	Price
P3-04DA	4	Analog Output	<--->
P3-08DA-1	8	Analog Output (Current)	<--->
P3-08DA-2	8	Analog Output (Voltage)	<--->
P3-06DAS-1	6	Isolated Analog Output (Current)	<--->
P3-06DAS-2	6	Isolated Analog Output (Voltage)	<--->
P3-16DA-1	16	Analog Output (Current)	<--->
P3-16DA-2	16	Analog Output (Voltage)	<--->

Productivity3000 Analog Input/Output Modules			
Part Number	Number of Channels	Description	Price
P3-8AD4DA-1	8/4	Analog Input/Output (Current)	<--->
P3-8AD4DA-2	8/4	Analog Input/Output (Voltage)	<--->

## Discrete Output Modules

Productivity3000 Discrete Output Modules			
Part Number	Number of Outputs	Description	Price
P3-08TD1S	8	Isolated Sinking Output	<--->
P3-08TD2S	8	Isolated Sourcing Output	<--->
P3-16TD1	16	Sinking Output	<--->
P3-16TD2	16	Sourcing Output	<--->
P3-32TD1*	32	Sinking Output	<--->
P3-32TD2*	32	Sourcing Output	<--->
P3-64TD1*	64	Sinking Output	<--->
P3-64TD2*	64	Sourcing Output	<--->
P3-08TAS	8	Isolated AC Output	<--->
P3-16TA	16	AC Output	<--->
P3-08TRS	8	Isolated Relay Output	<--->
P3-16TR	16	Relay Output	<--->
P3-08TRS-1	8	Isolated Relay Output	<--->

\*ZIPLink required.

## Module Installation Procedure

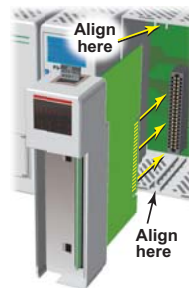

**WARNING:** Do not apply field power until the following steps are completed. See hot-swapping procedure for exceptions.

**Step One:** Align circuit card with slot and press firmly to seat module into connector.

**Step Two:** Pull top and bottom locking tabs toward module face. Click indicates lock is

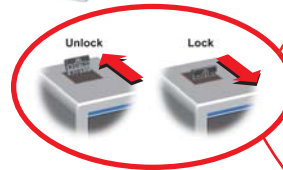

**Step Three:** Attach field wiring using optional terminal block or ZIPLink wiring system and install cover.



To install or remove terminal block cover, press middle to flex cover.



**WARNING:** Explosion hazard – Do not connect or disconnect connectors or operate switches while circuit is live unless the area is known to be non-hazardous. Do not hot-swap modules unless the area is known to be non-hazardous.