

# Relay Output Module

## P3-08TRS-1



### Isolated Relay Output

The P3-08TRS-1 High-Current Isolated Relay Output Module provides eight 5A relay outputs with eight fused commons.

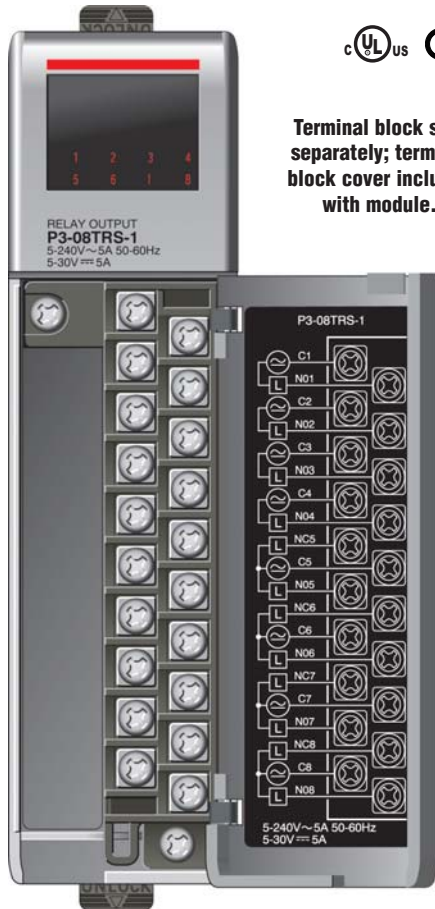

**Terminal block sold separately; terminal block cover included with module.**

Output Specifications	
Outputs per Module	8 relays (non-latching)
Commons per Module	8 (isolated)
Operating Voltage Range (Tolerance)	(CE) 6.25-24 VDC (-15% / +20%) 6-240 VAC (-15% / +10%)
	(UL) 5-30 VDC (-0% / +10%) 5-240 VAC (-0% / +10%)
Output Type	4 Form C (SPDT-NO/NC), 4 Form A (SPST-NO)
AC Frequency	47-63 Hz
On Voltage Drop	Minimal (90 mV max for fuse at 10A)
Max Output Current @ Temperature (Resistive)*	6.3A at 23°C, 5.0A at 60°C For both AC and DC
Maximum Leakage Current	Minimal (5 µA for TVS diode)
Minimum Load	10 mA @ 5 VDC
Maximum Inrush Current	12A
External DC Required	None
OFF to ON Response	10 ms
ON to OFF Response	5 ms (Excluding NO bounce)
Terminal Type (not included)	20-position removable terminal block
Status Indicators	Logic side
Fuses	6.3A user replaceable fuse per common For replacement, order P3-FUSE-2 (5/Pkg.)
Dielectric Strength (Between normally open and normally closed contacts on the same relay)	1500 VAC @ 1 min logic to output and isolated output to output, 750 VAC @ 1 min between contacts on same relay (Same as 1800 VAC @ 1 sec and 900 VAC @ 1 sec)
Transient Voltage Suppression (Bi-directional TVS diode)	482V clamp at 1.25A peak pulse current
Mechanical Life Expectancy	>100,000 at 30 operations per minute

\*Rating is for a normally-open contact. Normally-closed contacts have 1/2 the current handling capability.

Typical Relay Life*		
Voltage & Type of Load	Operating Current	Operations
24VDC Resistive	6.3A	600,000
24VDC Solenoid	0.2A	1,000,000
120VAC Resistive	6.3A	600,000
120VAC Resistive	3A	1,000,000
120VAC Solenoid	0.5A	500,000
240VAC Resistive	6.3A	450,000
240VAC Resistive	3A	600,000
1/4 HP Motor	1.5 x FLA (motor)	30,000

\*Ratings are for normally-open contacts. Normally-closed contacts have 1/2 the current handling capability.

### Output Derating

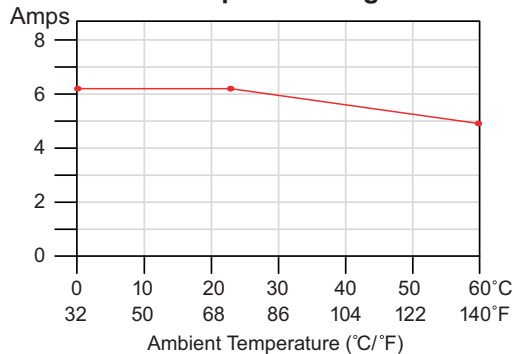

**All 8 outputs on, 100% duty cycle allowed.**

We recommend using prewired ZIPLink cables and connection modules. See "Wiring Systems".

Terminal block cover included. If you wish to hand-wire your module, a removable terminal block is sold separately. Order part number P3-RTB.



Removable Terminal Block Specifications	
Description	Part No. P3-RTB; 20 screw terminals
Wire Range	22-14 AWG (0.324 to 2.08 sq. mm) Solid / stranded conductor 3/64 in. (1.2 mm) insulation maximum "USE COPPER CONDUCTORS , 60°C" or equivalent.
Screw Driver Width	1/4 inch (6.5 mm) maximum
Screw Size	M3 size
Screw Torque	Field terminals – 7 - 9 in./lb (.0882 - 1.02 Nm) Self-jacking screws – 2.7 - 3.6 in./lb (0.3 - 0.4 Nm). Do not overtighten screws when installing terminal block.

**WARNING: Explosion hazard – Substitution of components may impair suitability for Class I, Division 2.**

# Relay Output Module

## P3-08TRS-1 (Cont'd)

General Specifications	
Operating Temperature	0° to 60°C (32° to 140°F),
Storage Temperature	-20° to 70°C (-4° to 158°F)
Humidity	5 to 95% (non-condensing)
Environmental Air	No corrosive gases permitted
Vibration	MIL STD 810C 514.2
Shock	MIL STD 810C 516.2
Field to Logic Side Isolation	1800VAC applied for 1 second
Insulation Resistance	>10MΩ @ 500 VDC
Heat Dissipation	3W
Enclosure Type	Open Equipment
Agency Approvals	UL508 file E157382, Canada & USA UL1604 file E200031, Canada & USA CE (EN61131-2*) This equipment is suitable for use in Class 1, Division 2, Groups A, B, C and D or non-hazardous locations only.
Module Keying to Backplane	Electronic
Module Location	Any I/O slot in any local, expansion, or remote base in a Productivity3000 System.
Field Wiring	Removable terminal block (not included). Use Z/PLink wiring system or optional terminal block. See "Wiring I/O Modules".
EU Directive	See the "EU Directive" topic in the Productivity3000 Help File. Information can also be obtained at: <a href="http://www.productivitypac.com">www.productivitypac.com</a>
Terminal Type (not included)	20-position removable terminal block
Weight	286g (10.08 oz)

\*Meets EMC and Safety requirements. See the Declaration of Conformity for details.

### Replaceable Fuses

Order Part Number P3-FUSE-2 (Qty. 5/Pkg.) One spare included with this module.

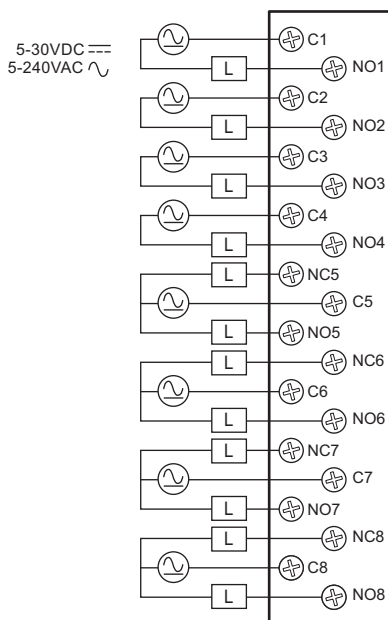
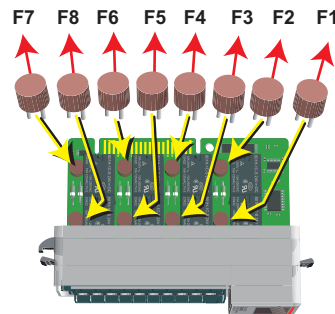

#### Outputs NO1 - NO4

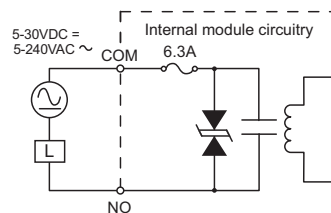

#### Outputs NO5 / NC5 - NO8 / NC8

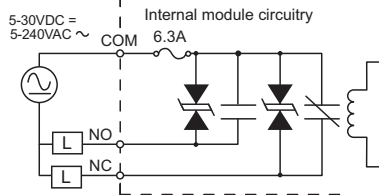



## Specify your ZIPLink system

Use the Compatibility Matrix table below.

<b>Step 1</b>	Locate the I/O module part number.
<b>Step 2</b>	Locate Connector Module Type. (Feedthrough Module, Fuse Module, etc...)
<b>Step 3</b>	Select the cable length by replacing the # symbol with: Blank = 0.5m, -1 = 1.0m, -2 = 2.0m <sup>1</sup>
<sup>1</sup> Note: Cable part number denotes compatibility between Connector Module and I/O Modules.	

Productivity3000 ZIPLink Wiring System Compatibility Matrix								
Step 2: Connector Module Type		Feedthrough Modules		Fuse Modules		Relay Module	Sensor Input Mod.	Pigtail Cable
Step 1: I/O Module	Number of Terminals	ZL-RTB20	ZL-RTB40	ZL-RFU20	ZL-RFU40	ZL-RRL16-24	ZL-LTB16-24	
Step 3: Cables								
<b>Inputs</b>								
<b>P3-08NAS</b>	20	ZL-P3-CBL20#						ZL-P3-CBL20-#P
<b>P3-08ND3S</b>	20	ZL-P3-CBL20#						ZL-P3-CBL20-#P
<b>P3-16NA</b>	20	ZL-P3-CBL20L#						ZL-P3-CBL20-#P
<b>P3-16ND3</b>	20	ZL-P3-CBL20L#						ZL-P3-CBL20-#P
<b>P3-32ND3</b>	40		ZL-CBL40#				ZL-P3-CBL40#	
<b>P3-64ND3*</b>	40		ZL-CBL40#				ZL-P3-CBL40#	
<b>Outputs</b>								
<b>P3-08TAS</b>	20	ZL-P3-CBL20#						ZL-P3-CBL20-#P
<b>P3-08TD1S</b>	20	ZL-P3-CBL20L#						ZL-P3-CBL20-#P
<b>P3-08TD2S</b>	20	ZL-P3-CBL20L#						ZL-P3-CBL20-#P
<b>P3-08TRS</b>	20	ZL-P3-CBL20#						ZL-P3-CBL20-#P
<b>P3-16TA</b>	20	ZL-P3-CBL20#		ZL-P3-CBL20L#				ZL-P3-CBL20-#P
<b>P3-16TD1</b>	20	ZL-P3-CBL20#		ZL-P3-CBL20#		ZL-P3-CBL20#		ZL-P3-CBL20-#P
<b>P3-16TD2</b>	20	ZL-P3-CBL20#		ZL-P3-CBL20#				ZL-P3-CBL20-#P
<b>P3-16TR</b>	20	ZL-P3-CBL20#		ZL-P3-CBL20#				ZL-P3-CBL20-#P
<b>P3-08TRS-1***</b>	20	ZL-P3-CBL20#						ZL-P3-CBL20-#P
<b>P3-32TD1</b>	40		ZL-CBL40#		ZL-CBL40#			
<b>P3-32TD2</b>	40		ZL-CBL40#		ZL-CBL40#			
<b>P3-64TD1*</b>	40		ZL-CBL40#		ZL-CBL40#			
<b>P3-64TD2*</b>	40		ZL-CBL40#		ZL-CBL40#			
<b>Analog In</b>								
<b>P3-04ADS</b>	20	ZL-P3-CBL20L#						ZL-P3-CBL20-#P
<b>P3-08AD</b>	20	ZL-P3-CBL20L#						ZL-P3-CBL20-#P
<b>P3-16AD-1</b>	20	ZL-P3-CBL20L#						ZL-P3-CBL20-#P
<b>P3-16AD-2</b>	20	ZL-P3-CBL20L#						ZL-P3-CBL20-#P
<b>P3-08RTD**</b>	Matched Only							
<b>P3-08THM**</b>	T/C Wire Only							
<b>Analog Out</b>								
<b>P3-04DA</b>	20	ZL-P3-CBL20L#						ZL-P3-CBL20-#P
<b>P3-08DA-1</b>	20	ZL-P3-CBL20L#						ZL-P3-CBL20-#P
<b>P3-08DA-2</b>	20	ZL-P3-CBL20L#						ZL-P3-CBL20-#P
<b>P3-06DAS-1</b>	20	ZL-P3-CBL20L#						ZL-P3-CBL20-#P
<b>P3-06DAS-2</b>	20	ZL-P3-CBL20L#						ZL-P3-CBL20-#P
<b>P3-16DA-1</b>	20	ZL-P3-CBL20L#						ZL-P3-CBL20-#P
<b>P3-16DA-2</b>	20	ZL-P3-CBL20L#						ZL-P3-CBL20-#P
<b>Analog Combo</b>								
<b>P3-8AD4DA-1</b>	20	ZL-P3-CBL20L#						ZL-P3-CBL20-#P
<b>P3-8AD4DA-2</b>	20	ZL-P3-CBL20L#						ZL-P3-CBL20-#P

\*The P3-64ND3, P3-64TD1, and P3-64TD2 modules have two 32-point connectors and require 2 ZIPLink cables and 2 ZIPLink connector modules.

\*\*These modules are not supported by the ZIPLink wiring system. Removable terminal block P3-RTB included.

\*\*\*The P3-08TRS-1 output module is derated, not to exceed 2A per point maximum when used with the ZIPLink wiring system.

# I/O Modules

A variety of discrete and analog I/O modules are available for use in local, expansion, and remote I/O bases. Specifications for each module are on the following pages.

A filler module is available for unused I/O module slots (part number P3-FILL).



## Discrete Input Modules

Productivity3000 Discrete Input Modules			
Part Number	Number of Inputs	Description	Price
P3-16SIM	16	Input Simulator Module	<--->
P3-08ND3S	8	Isolated Sinking/Sourcing DC Input	<--->
P3-16ND3	16	Sinking/Sourcing DC Input	<--->
P3-32ND3*	32	Sinking/Sourcing DC Input	<--->
P3-64ND3*	64	Sinking/Sourcing DC Input	<--->
P3-08NAS	8	Isolated AC Input	<--->
P3-16NA	16	AC Input	<--->

\*ZIPLink required.

## Analog I/O Modules

Productivity3000 Analog Input Modules			
Part Number	Number of Channels	Description	Price
P3-04ADS	4	Isolated Analog Input	<--->
P3-08AD	8	Analog Input	<--->
P3-16AD-1	16	Analog Input (Current)	<--->
P3-16AD-2	16	Analog Input (Voltage)	<--->
P3-08RTD	8	Analog RTD Input	<--->
P3-08THM	8	Analog Thermocouple Input	<--->

Productivity3000 Analog Output Modules			
Part Number	Number of Channels	Description	Price
P3-04DA	4	Analog Output	<--->
P3-08DA-1	8	Analog Output (Current)	<--->
P3-08DA-2	8	Analog Output (Voltage)	<--->
P3-06DAS-1	6	Isolated Analog Output (Current)	<--->
P3-06DAS-2	6	Isolated Analog Output (Voltage)	<--->
P3-16DA-1	16	Analog Output (Current)	<--->
P3-16DA-2	16	Analog Output (Voltage)	<--->

Productivity3000 Analog Input/Output Modules			
Part Number	Number of Channels	Description	Price
P3-8AD4DA-1	8/4	Analog Input/Output (Current)	<--->
P3-8AD4DA-2	8/4	Analog Input/Output (Voltage)	<--->

## Discrete Output Modules

Productivity3000 Discrete Output Modules			
Part Number	Number of Outputs	Description	Price
P3-08TD1S	8	Isolated Sinking Output	<--->
P3-08TD2S	8	Isolated Sourcing Output	<--->
P3-16TD1	16	Sinking Output	<--->
P3-16TD2	16	Sourcing Output	<--->
P3-32TD1*	32	Sinking Output	<--->
P3-32TD2*	32	Sourcing Output	<--->
P3-64TD1*	64	Sinking Output	<--->
P3-64TD2*	64	Sourcing Output	<--->
P3-08TAS	8	Isolated AC Output	<--->
P3-16TA	16	AC Output	<--->
P3-08TRS	8	Isolated Relay Output	<--->
P3-16TR	16	Relay Output	<--->
P3-08TRS-1	8	Isolated Relay Output	<--->

\*ZIPLink required.

## Module Installation Procedure

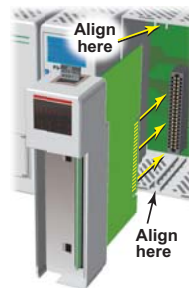

**WARNING:** Do not apply field power until the following steps are completed. See hot-swapping procedure for exceptions.

**Step One:** Align circuit card with slot and press firmly to seat module into connector.

**Step Two:** Pull top and bottom locking tabs toward module face. Click indicates lock is

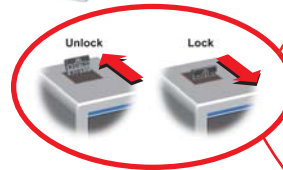

**Step Three:** Attach field wiring using optional terminal block or ZIPLink wiring system and install cover.



To install or remove terminal block cover, press middle to flex cover.



**WARNING:** Explosion hazard – Do not connect or disconnect connectors or operate switches while circuit is live unless the area is known to be non-hazardous. Do not hot-swap modules unless the area is known to be non-hazardous.